



*Fire Your Imagination*

# Riva2 500

**Inset Convectur Fire - Balanced Flue  
with Thermostatic Remote Control**



**IMPORTANT:**  
FOR EASY TO FOLLOW,  
STEP BY STEP VIDEO  
INSTRUCTIONS ON HOW TO  
OPERATE AND MAINTAIN YOUR  
GAZCO REMOTE SYSTEM GO TO  
[WWW.GAZCO.TV](http://WWW.GAZCO.TV)

## Instructions for Use, Installation & Servicing

For use in GB & IE (Great Britain & Republic of Ireland).

### **IMPORTANT**

**THE OUTER CASING, FRONT AND GLASS PANEL BECOME EXTREMELY HOT DURING OPERATION AND WILL RESULT IN SERIOUS INJURY AND BURNS IF TOUCHED. IT IS THEREFORE RECOMMENDED THAT A FIREGUARD COMPLYING WITH BS 8423:2002 IS USED IN THE PRESENCE OF YOUNG CHILDREN, THE ELDERLY OR INFIRM.**

This product contains a Heat resistant glass panel. This panel should be checked during Installation and at each servicing interval. If any damage is observed on the front face of the glass panel (scratches, scores, cracks or other surface defects), the glass panel must be replaced and the appliance must not be used until a replacement is installed. Under no circumstances should the appliance be used if any damage is observed, the glass panel is removed or broken.

It is essential that ALL of the screws that retain the glass frame are replaced and tightened correctly. Under no circumstances should the appliance be operated if any of these screws are loose or missing.

These Instructions must be left with the appliance for future reference and for consultation when servicing the appliance. Please make the customer aware of the correct operation of the appliance before leaving these instructions with them.

The commissioning sheet found on Page 3 of this Instruction manual must be completed by the Installer prior to leaving the premises.

# Contents

## Riva2 500 - Balanced Flue

Covering the following models:

Riva2 500 Nat Gas	Riva2 500 LPG
134-249	134-401

<b>Appliance Commissioning Checklist .....</b>	<b>3</b>
<b>User Instructions.....</b>	<b>4</b>
<b>Installation Instructions.....</b>	<b>15</b>
Technical Specifications .....	15
Site Requirements.....	17
Installation .....	21
Commissioning.....	36
<b>Servicing Instructions.....</b>	<b>37</b>
Fault Finding.....	37
How to Replace Parts .....	40
Basic Spare Parts List.....	47
Service Records .....	48



To receive your Extended Warranty your Gazco appliance must have been purchased from our Expert Retailer Network and registered within one month of purchase or installation. Please note that all warranties are effective from the date of purchase. Any Gazco product purchased outside of our Extended Retailer Network, or not registered within the stated time will carry a standard 12 month warranty.

It is a condition of the Extended Warranty that the installation complies with the relevant Building Regulations and is carried out by a suitably trained and qualified individual (GasSafe in the UK or equivalent in other countries) with the certificate of installation and the Commissioning Report on Page 3 completed and retained by the end user.

Full terms and conditions are detailed in the Warranty Statement on the Gazco website [www.gazco.com](http://www.gazco.com). In the event of any conflict of information the wording on the website shall prevail.

**Important Note:** Should any problems be experienced with your product, claims must first be submitted to the Expert Retailer where the appliance was purchased from who will offer immediate assistance or contact Gazco on your behalf.

# Appliance Commissioning Checklist

To assist us in any guarantee claim please complete the following information:-

## IMPORTANT NOTICE

Explain the operation of the appliance to the end user, hand the completed instructions to them for safe keeping, as the information will be required when making any guaranteed claims.

FLUE CHECK	PASS	FAIL
1. Flue Is correct for appliance		
2. Flue flow Test		
3. Spillage Test		
GAS CHECK		
1. Gas soundness & let by test		
2. Standing gas pressure	mb	
3. Appliance working pressure (on High Setting NB All other gas appliances must be operating on full	mb	
4. Gas rate	m <sup>3</sup> /h	
5. Does Ventilation meet appliance requirements		
SAFETY CHECK		
1. Glass checked to ensure no damage, scratches, scores or cracks.		
2. Glass frame secured correctly and all screws replaced		

## RETAILER AND INSTALLER INFORMATION

Retailer.....  
 .....  
 .....  
 Contact No.....  
 Date of Purchase.....  
 Model No. ....  
 Serial No.....  
 Gas Type .....

Installation Company.....  
 .....  
 .....  
 Engineer.....  
 Contact No.....  
 Gas Safe Reg No. ....  
 Date of Installation .....

# User Instructions

## Welcome

*Congratulations on purchasing your Riva2 fire, if installed correctly Gazco hope it will give you many years of warmth and pleasure for which it was designed.*

*The purpose of this manual is to familiarise you with your appliance, and give guidelines for its installation, operation and maintenance. If, after reading, you need further information, please do not hesitate to contact your Gazco retailer.*

## WARNING



**In the event of a gas escape or if you can smell gas, please take the following steps:**

- Immediately turn off the gas supply at the meter/emergency control valve
- Extinguish all sources of ignition
- Do not smoke
- Do not operate any electrical light or power switches (On or Off)
- Ventilate the building(s) by opening doors and windows
- Ensure access to the premises can be made

**Please report the incident immediately to the National Gas Emergency Service Call Centre on 0800 111 999 (England, Scotland and Wales) , 0800 002 001 (N. Ireland) or in the case of LPG, the gas supplier whose details can be found on the bulk storage vessel or cylinder.**

**The gas supply must not be used until remedial action has been taken to correct the defect and the installation has been recommissioned by a competent person.**

## 1. General

- 1.1 Installation and servicing must only be carried out by a competent person whose name appears on the Gas Safe register. To ensure the engineer is registered with Gas Safe they should possess an ID Card carrying the following logo:



- 1.2 In all correspondence, please quote the appliance type and serial number, which can be found on the data badge located on a plate attached to the lower slotted trim.
- 1.3 Do not place curtains above the appliance: You must have 300mm (1') clearance between the appliance and any curtains at either side.
- 1.4 No furnishings or other objects should be placed within 1 metre of the front of the appliance.
- 1.5 If a shelf is fitted, a distance of 400mm above the appliance is required.
- 1.6 If any cracks appear in the glass panel do not use the appliance until the panel has been replaced.
- 1.7 If, for any reason, the flue has to be removed from the appliance, the seals must be replaced in the inner spigot.
- 1.8 Do not obstruct the flue terminal in any way, i.e. by planting flowers, trees, shrubs etc. in the near vicinity, or by leaning objects against the terminal guard.
- 1.9 Do not put any objects on the terminal guard; it will lose its shape.
- 1.10 If you use a garden sprinkler, do not let quantities of water into the flue terminal.
- 1.11 In the unlikely event the appliance is receiving interference from other electronic devices, the handset/Control box can be reprogrammed. Please refer to the commissioning section in order to change the communication channel.
- 1.12 This product is guaranteed for 5 years from the date of installation, as set out in the terms and conditions of sale between Gazco and your local Gazco retailer. Please consult with your local Gazco retailer if you have any questions. In all correspondence always quote the Model Number and Serial Number.

# User Instructions

## 2. Control Options

- 2.1 The appliance has 4 flame settings:
1. High.
  2. Medium.
  3. Low.
  4. Standby (Pilot only).
- 2.2 Both touch pad and handset allow you to manually switch between flame settings.
- 2.3 The Thermostatic handset also allows to set the appliance to automatically regulate the room temperature.

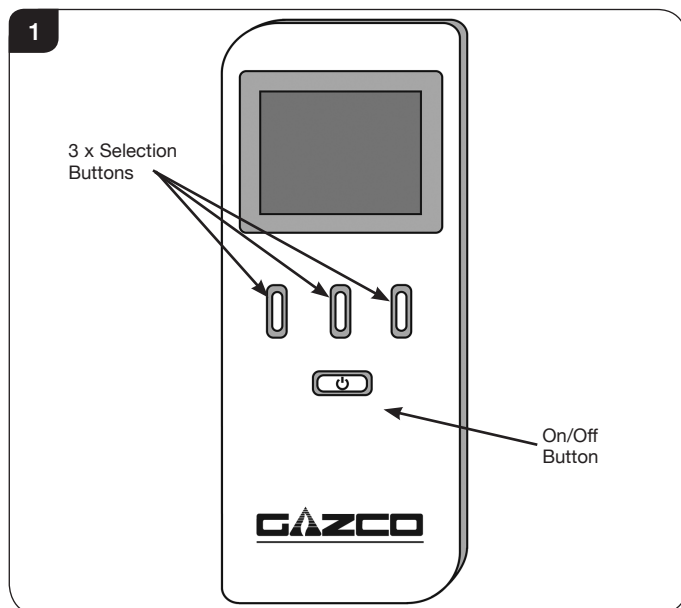

### Before using the remote control:

- 2.4 If there is no display on the LCD screen press any key.
- 2.5 When first powered, the handset displays the OFF screen. The handset may be locked as indicated by the padlock symbol (🔒), see Diagram 2.

**NOTE: To select a function from the options displayed at the bottom of the screen press the button directly below the desired function.**

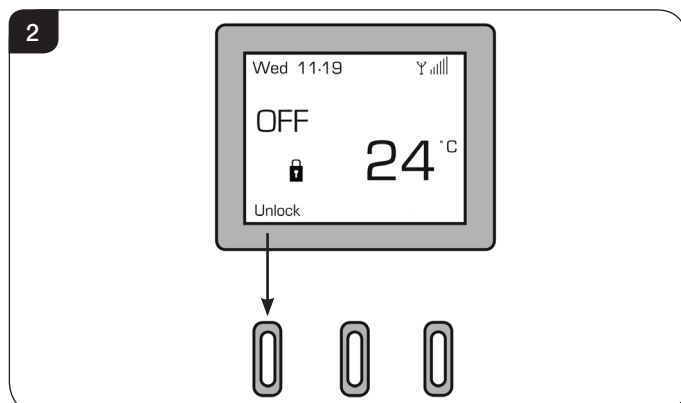

- 2.6 To unlock the handset select Unlock followed by OK - the symbol will change to an open padlock (🔓).

- 2.7 There are 3 different modes available for controlling and operating the appliance:

1. Manual Mode - See Page 6.
2. Automatic Mode - See Page 6.
3. Program Mode - See Page 7.

When a command from the handset is received a beep will sound and the LED on the handset will briefly illuminate.

**NOTE:** The LED flashes every 4 seconds to show that it is communicating with the appliance. After each command has been accepted the LED will cease flashing until the command has been carried out. Wait until the LED resumes flashing before giving another command.

## Advanced Controls

- 2.8 The thermostatic remote control handset has been pre-set as follows:
- a) Thermostat mode - the appliance will alter automatically to achieve and maintain a desired room temperature in Auto (Fixed Temp) or Program mode.
  - b) Gap temperature set at 2°C - in Auto or Program mode the appliance will automatically ignite if the room temperature falls 2°C below the fixed temperature.
  - c) Program mode enabled - this allows one of three temperatures (Night temperature, Comfort temperature or Off) to be set for each hour of the day on a daily or weekly cycle.
  - d) Soft start enabled - in Auto or Program mode there is a 10 second delay between flame settings when more than one change of setting is required (i.e. from High to Low).
  - e) Sounder ON - the appliance will beep to confirm that it has received a command from the handset or touch pad.
  - f) Safety Temperature pre-set at 40°C - the appliance will automatically switch off if the room temperature (as displayed on the handset) exceeds 40°C.

**NOTE: If the Safety Temperature is exceeded the appliance can not be turned on again until the room temperature has dropped below the safety temperature.**

- 2.9 The LCD screen displays the following information, see Diagram 3.

- 1) Time (24 hr clock)
- 2) Signal strength (between handset and appliance)
- 3) Selected Setting - set fixed temperature (in degrees) when in Auto mode (small number)
- 4) Current room temperature (large number)
- 5) Button function
- 6) Child lock status (shown by open or closed padlock)

# User Instructions

- 7) Current flame status (Low, Med, High)
- 8) Selected Mode - Manual Flame / Fixed Temp (Auto) / Program - when appliance is switched on
- 9) Day of the week (Mon - Sun)

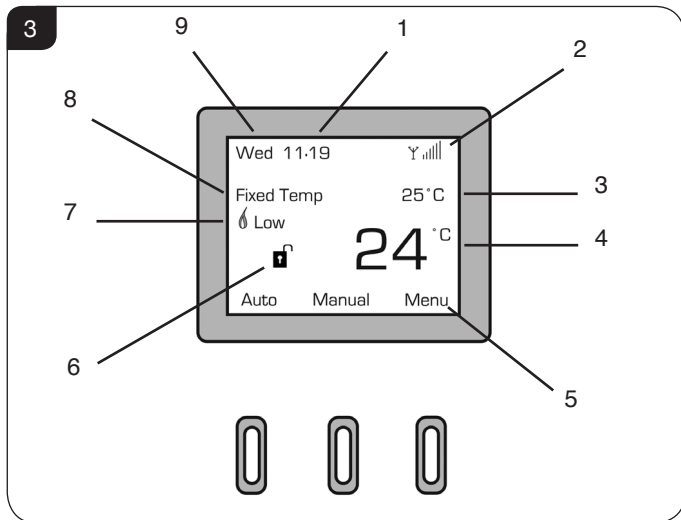

## 1. Manual Mode

### Switching the Appliance ON:

2.10 To light the appliance press the On/Off (⏻) button, this will bring up the LCD screen. Select the 'On' option on the left of the screen immediately followed directly by the OK button, a single beep will sound.

After the start up cycle has completed the appliance will light on the high flame setting (this can take up to 20 seconds).

Select the 'Manual' option on the screen to control the appliance.

### Decreasing the Flame Height:

- 2.11 From the high flame setting press DOWN (↓) once to lower the flame to the medium setting.
- 2.12 From the medium flame setting press DOWN (↓) once to lower the flame to the low setting.
- 2.13 From the low flame setting press DOWN (↓) once to put the appliance in Standby mode (Pilot only).

### Increasing the Flame Height:

- 2.14 To light the appliance when it is in Standby mode press UP (↑) once. The appliance will light on the **Low** flame setting.
- 2.15 From the low setting press UP (↑) once to increase the flame setting to medium.
- 2.16 From the medium setting press UP (↑) once to increase the flame setting to high.



**WARNING: IF THE APPLIANCE FAILS TO LIGHT OR BECOMES EXTINGUISHED IN USE, WAIT 3 MINUTES BEFORE ATTEMPTING TO RELIGHT.**



**IMPORTANT: YELLOW FLAMES TYPICALLY APPEAR WHEN THE APPLIANCE HAS REACHED NORMAL OPERATING TEMPERATURE. THIS CAN TAKE UP TO 30 MINUTES.**

### Switching the Appliance OFF:

2.17 To switch the appliance OFF press the On/Off (⏻) button once, see Diagram 1.

## 2. Automatic Mode

Auto mode allows you to pre-set a room temperature. The appliance controls the flame setting automatically to achieve and maintain this temperature.

**NOTE: WHEN IN AUTOMATIC MODE, THE PILOT REMAINS LIT AND THE MAIN BURNER AUTOMATICALLY ADJUSTS TO MAINTAIN THE FIXED TEMPERATURE WHETHER OR NOT ANYONE IS IN THE ROOM.**

- 2.18 If the appliance is switched off, select On followed by OK. The appliance will emit a single beep and the pilot will light.
- 2.19 Select Auto. The screen will display the word 'Thermo' and the current fixed room temperature will be highlighted.
- 2.20 Use the buttons directly below the up (↑) or down (↓) symbols to select a temperature between 0°C and 37°C.  
  
The flame setting required to achieve the desired room temperature will now be displayed below the word 'Thermo'.
- 2.21 The appliance will maintain the fixed temperature by automatically adjusting the flame height as follows:
  - a) If the room temperature falls 1°C below the fixed temperature the flame height will increase.
  - b) If the room temperature rises 1°C above the fixed temperature the flame height will decrease.
  - c) There will be a delay of 10 seconds between each flame setting adjustment.
- 2.22 Once the desired room temperature has been set, select Back to return to the main screen.
- 2.23 The screen will now display the words 'Fixed Temp', the chosen fixed temperature (e.g. 25°C) and the current room temperature (e.g. 24°C), see Diagram 4.

4

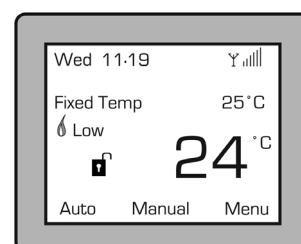

# User Instructions

- 2.24 To change the fixed temperature at any time select Auto and follow 2.20.
- 2.25 To exit the Auto mode at any time select Manual and follow Section 2.22.
- 2.26 To turn off the appliance press the ON/OFF button once, see Diagram 2.

## Setting the Display

Items displayed on the main screen, such as day and time, can be set using the Adjust Menu function.

- 2.27 To access the Adjust Menu function select Menu from the main screen.
- 2.28 Select Adjust Menu.  
In this menu it is possible to set the:
- Temperature Unit (°C/°F)
  - Language
  - Autolock (On/Off)
  - Day (Mon - Sun)
  - Hour (24hr clock)
  - Minute
  - Comfort temperature (for use when in Program mode)
  - Night temperature (for use when in Program mode)

Access can be gained to the programmable functions via the Change Prog option (see Programming the Appliance).

### Setting the Day and Time:

- 2.29 Use (↓) to scroll down to Day and press Select.  
Use (↑) and (↓) to set the day of the week.
- 2.30 Press Back and scroll down to Hour and select it.  
Use (↑) and (↓) to set the hour.
- 2.31 Press Back and scroll down to Minute and press Select.  
Use (↑) and (↓) to set the minutes.
- 2.32 The same process can be used to set any of the functions within this menu.

## 3. Program Mode

Program mode allows the appliance to be pre-set to a choice of temperature options on a daily or weekly cycle. The appliance will automatically switch on and off and control the flame setting to maintain pre-set hourly temperatures during each 24hr period.

**NOTE: WHEN IN PROGRAM MODE, THE PILOT REMAINS LIT AND THE MAIN BURNER AUTOMATICALLY SWITCHES ON AT THE PROGRAMMED TIMES AND ADJUSTS THE FLAME HEIGHT TO BRING THE ROOM TO THE SET TEMPERATURE WHETHER OR NOT ANYONE IS IN THE ROOM.**

**Note: The current day and time must be set in order for the programmable functions to work. (See Section 2.28 for details).**

- 2.33 There are two types of program mode:
1. Daily - the temperature can be set for each hour over a 24hr period - This pattern is then repeated every day.
  2. Weekly - the temperature can be set for each hour over a 24hr period for each individual day of the week (Mon - Sun). This pattern is then repeated every week.
- 2.34 One of 3 options can be chosen for each hour across a 24 hour period:
- Off - the appliance will remain in Standby mode (pilot only). **The appliance will not switch off completely when in Program mode.**
  - Night Temp - the appliance will automatically maintain a pre-set night temperature.
  - Comfort Temp - the appliance will automatically maintain a pre-set comfort temperature.
- 2.35 To set the Comfort and Night temperature select Menu. In the next screen select Adjust Menu. Using (↓) scroll to Comfort Temperature and select. Use (↑) and (↓) to set a chosen temperature. Repeat for Night Temperature.
- 2.36 To access the programming screen select Menu. In the next screen select Adjust Menu. Using (↓) scroll to Change Prog and select. The programming screen will be displayed as shown in Diagram 5.

5

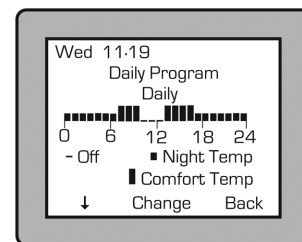

### Setting Daily Operating Times:

- 2.37 In the program menu highlight the word 'Daily'. Press (↓) to access the 24 hour timer below 'Daily'. The arrow should now point to the right (→).

# User Instructions

- 2.38 The timer reads 0 - 24 with both 0 and 24 representing midnight. Press (→) to scroll through the 24 hour timer. With the cursor resting on the chosen hour, press Change until the desired setting for that hour (Comfort Temperature, Night Temperature or Off) is reached. Use (→) to scroll to the next hour and select the desired function for each hour until all 24 hours are set, see Diagram 6.

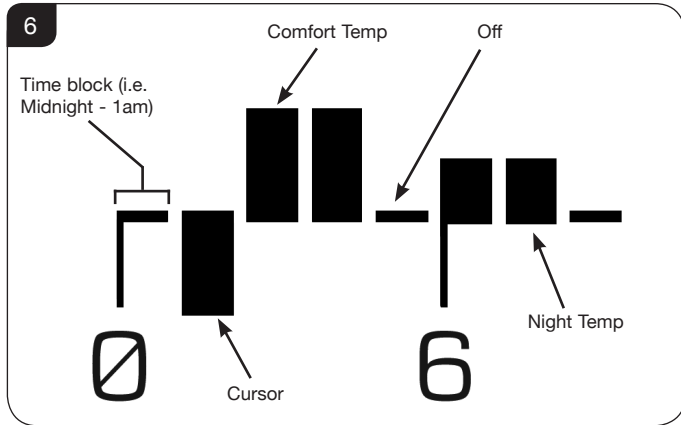

- 2.39 The program must now be launched. To do to this see Section 2.44.

## Setting Weekly Operating Times:

- 2.40 Access the programming screen as detailed in Section 2.36. The word 'Daily' will be highlighted. Select 'Change' to scroll from 'Daily' to the required day of the week (Monday - Sunday).
- 2.41 Press (↓) to access the timer. Select the function settings for each hour of the chosen day as detailed in 2.40. Repeat for the rest of the week.
- 2.42 Once the programming is completed select Back to return to the main screen.
- 2.43 The program must now be launched. To do to this see 2.44.

## Launching a Daily or Weekly Program:

- 2.44 Select Menu. In the next screen use (↓) to scroll to Program and confirm. Select Change until the highlighted text reads ON.

**Note: The appliance must be ON (pilot lit or any flame setting) in order to launch the program.**

- 2.45 Select Back and use (↓) to select Prog Type. Select Change until the desired program (Daily or Weekly) is highlighted. Select Back twice to return to the main screen.

## To Switch Off Program Mode

- 2.46 To switch off the set program select Stop from the options on the main screen. The appliance will switch to Stand-by (pilot only). Alternatively select Auto; this will end the program cycle and return to the main screen. The appliance will automatically adjust the flame height to maintain any previously set Fixed Temperature.

## Locking the Handset

- 2.47 To lock the handset Select Lock. If the option is not visible on the screen (i.e. when the appliance is lit) select Menu and scroll down to Lock. Press Select and use the Change function to scroll to Yes. The handset is now locked.

## 3. Replacing the Handset Batteries

- 3.1 **BEFORE USE:**  
Ensure the remote handset contains 2 x AA 1.5v alkaline batteries (provided). Always replace the batteries with high quality batteries (Duracell or similar).  
**DO NOT USE RECHARGEABLE BATTERIES.**
- 3.2 Communication between the handset and the appliance may take up to 2 minutes after batteries have been replaced, check the strength of the signal in the top right hand corner of the LCD display (Y III).
- 3.3 If communication is not regained after this time the control unit and the handset may need pairing. Please refer to Commissioning, Section 2, Pairing the Appliance.

## 4. Handset Troubleshooting



**IMPORTANT - THE CONTROL SYSTEM HAS BEEN PROGRAMMED TO CHANNEL 'C'. SOME HOUSEHOLD APPLIANCES MAY HAVE ALSO BEEN SET TO OPERATE ON THE SAME FREQUENCY. ALTHOUGH THIS HAS NO EFFECT ON THE SAFETY OF THE SYSTEM AN EXCESSIVE DELAY MAY BE ENCOUNTERED BETWEEN COMMANDS. IF THIS OCCURS FOLLOW THE INSTRUCTIONS IN COMMISSIONING SECTION 3 TO CHANGE THE CHANNEL.**

### CHANNEL SETTINGS

- 4.1 The appliance has been factory set to only communicate with the handset it is supplied with. It will not respond to any other remote control, even one from an identical appliance.

A replacement handset will need to be paired with the appliance before use. Please refer to Commissioning, Section 2, Pairing the Appliance.

### LOW BATTERY

- 4.2 If the batteries in the remote control handset become discharged the LCD display will show the message Low Battery.

Follow Section 3 - Replacing The Handset Batteries.

### REMOTE SIGNAL STRENGTH



**NOTE: If the handset is taken out of range the signal strength indicator will show 'Loss of Signal'. When the handset is returned to the appliance it will be necessary to press any button and wait for the signal indicator to recognise the handset. This can take up to 4 minutes**



# User Instructions

- 4.3 If the appliance does not respond to the handset, check the strength of the signal in the top right hand corner of the LCD display (Y<sub>||||</sub>).

No vertical bars next to the signal symbol (Y) means communication between the appliance and the handset has been lost. If the communication loss exceeds 18 minutes the appliance will emit 20 beeps and switch OFF. Try the following:

- 4.4 Move the handset closer to the appliance.  
4.5 Replace the batteries in the handset, see Section 3.  
4.6 If there is still no signal, operate the appliance using the touch pad control, see Section 5 and consult your installer or Gazco retailer.

## 5. Touch Pad Control

7



The touch pad control is located on the front of the wall switch and allows manual operation of the appliance, see Diagram 7.

With the touch pad it is possible to turn the appliance ON, OFF and control the flame setting.

NOTE: When using the touch pad buttons a beep will be emitted from the appliance to indicate an accepted command.

### Lighting the appliance

- 5.1 Press the On/Off button once.
- If the pilot fails to light, press the ON/OFF button to switch OFF. Wait for at least 30 seconds before attempting to relight.
- 5.2 After the start up cycle has completed the appliance will light on the **high flame setting** (this can take up to 20 seconds).
- If the appliance is in Standby mode, pressing the UP (^) button will cause the main burner to ignite on the **Low flame setting**.
- 5.3 To increase the flame height press the UP (^) button.

- 5.4 To decrease the flame height press the DOWN (v) button.  
5.5 When on the lowest flame setting pressing the Down (v) button will switch the appliance to Standby mode (pilot only).



**WARNING: IF THE APPLIANCE FAILS TO LIGHT OR BECOMES EXTINGUISHED IN USE, WAIT 3 MINUTES BEFORE ATTEMPTING TO RELIGHT.**



**IMPORTANT: YELLOW FLAMES TYPICALLY APPEAR WHEN THE APPLIANCE HAS REACHED NORMAL OPERATING TEMPERATURE. THIS CAN TAKE UP TO 30 MINUTES.**

### To Switch the Appliance OFF:

- 5.6 To turn the appliance **OFF** press the On/Off button once.

## Touch Pad Control Not Working

### If the appliance is not operating with the touch pad control:

- 5.7 Replace the batteries in the wall switch unit, see Section 6.  
5.8 If the appliance still fails to operate consult your installer or Gazco retailer.

## 6. Changing the Appliance Batteries

The appliance batteries are located behind the wall switch plate.

- 6.1 Undo the two screws securing the wall plate and gently bring it forward to expose the wires behind. Keep the wall plate supported, taking care not to put any strain on the wires, see Diagram 8.

8

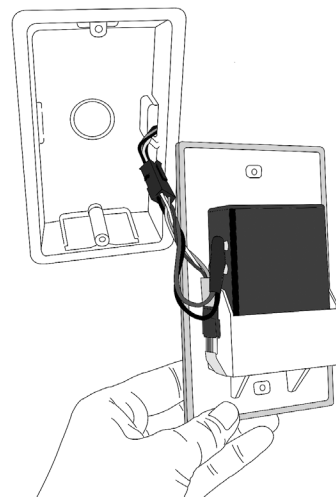

# User Instructions

6.2 Whilst supporting the wall plate remove the battery holder from its location, see Diagram 9.

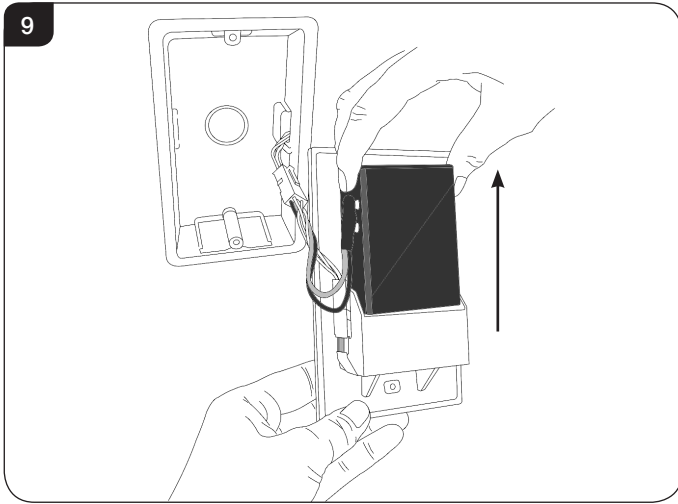

6.3 If it is not possible to support the wall plate and battery holder at the same time separate the wall plate from the dry lining box by disconnecting the plug as shown, see Diagram 10. Press the top of the clip on the upper section to release.

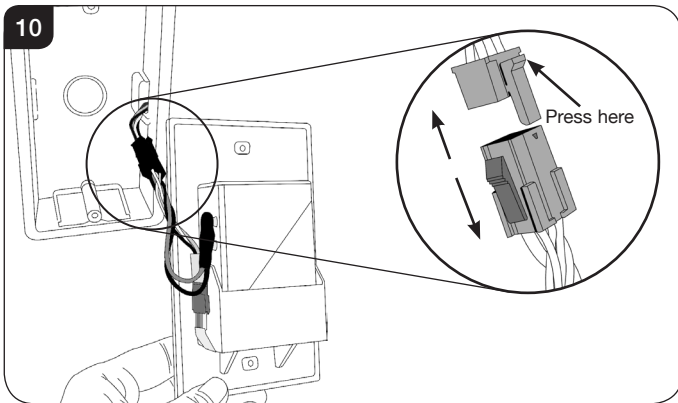

6.4 Flip the battery holder over end to end and remove the cover by sliding off in the direction of the arrow as shown in Diagram 11.

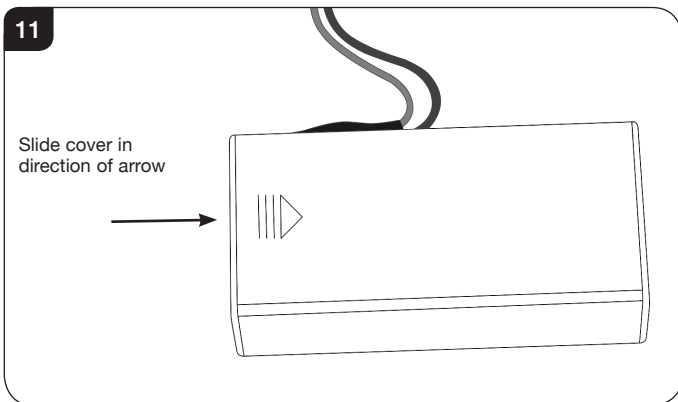

6.5 Remove the old batteries and correctly position the three new high quality (Duracell or similar) size C batteries into the battery holder, see Diagram 12.

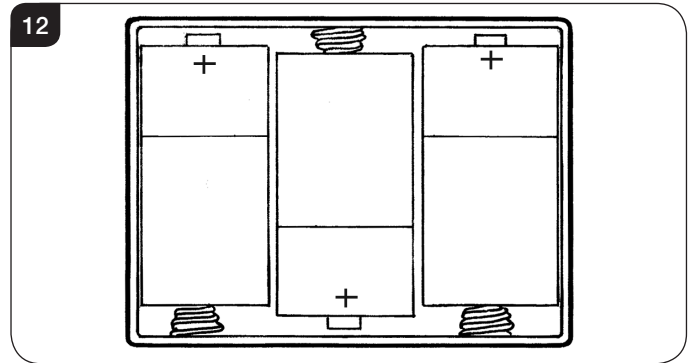

6.6 Re-assemble in reverse.

**PLEASE ENSURE NO WIRES ARE TRAPPED BEFORE REPLACING THE WALL PLATE. THE TOUCH PAD LEAD IS EASILY DAMAGED.**

## 7. Cleaning the Appliance

7.1 Make sure the appliance and surrounds are cool before cleaning.

7.2 Remove the glass frame by removing the 2 side trims, see Diagram 13. These are held on by magnets.

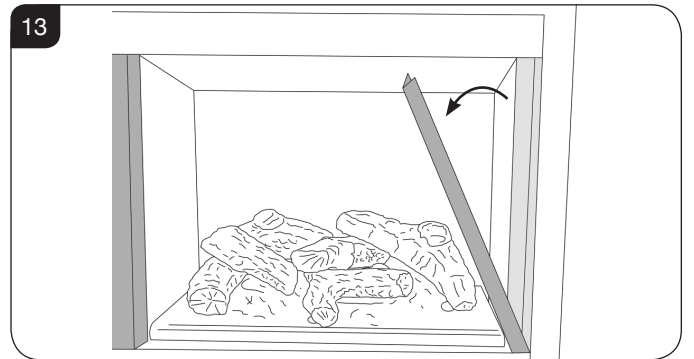

7.3 Lift out the bottom slotted trim, see Diagram 14. Note the orientation of the metal shield for reassembly.

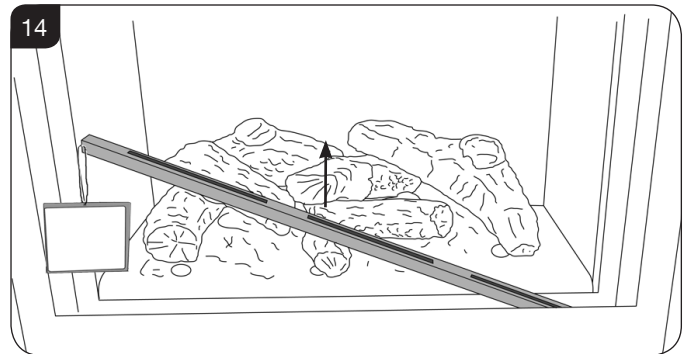

# User Instructions

- 7.4 Remove the 2 screws at the base of the glass frame, see Diagram 15.

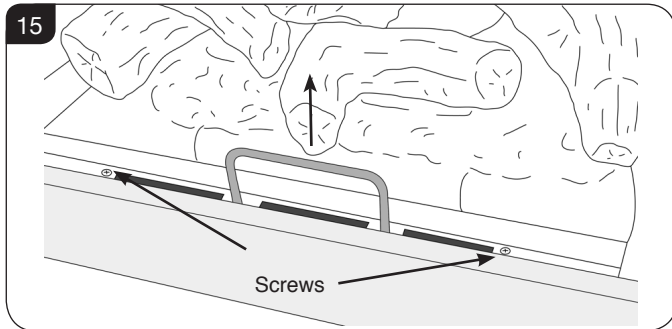

- 7.5 Pull up the handle at the front, see Diagram 15.  
7.6 Whilst supporting the top, lift the glass frame using the handle, up and over the lower edge, see Diagram 16.

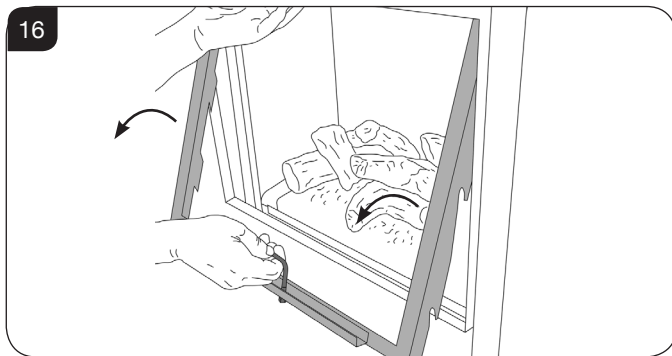

- 7.7 Remove the logs and Embaglow and place on a dry, clean surface.  
7.8 The logs should not require cleaning. Do not use a vacuum cleaner or brush to clean the logs, any large pieces of debris may be removed by hand.  
7.9 Ensure any debris is removed from the burner ports.  
7.10 Use a damp cloth to clean the outer casing of the appliance.  
7.11 To clean the glass surface use a non abrasive glass cleaner and soft cloth.  
**Ensure that the fibreglass seal on the back of the glass frame is intact.**  
7.12 To replace the glass frame, position so the hooks on the back of the frame fit over the side pins, see Diagram 17.

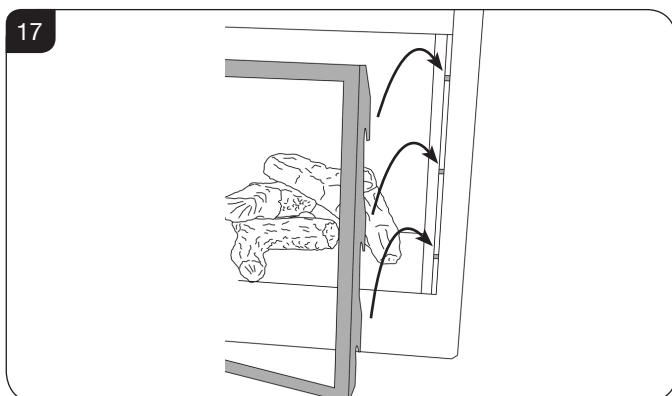

- 7.13 Push the handle down.  
7.14 Replace the screws. As the screws are tightened the glass frame is pulled down against the hooks and forms a seal. **Replace ALL of the securing screws ensuring that a screw is present in all fixing slots.**



**UNDER NO CIRCUMSTANCES SHOULD THE APPLIANCE BE USED IF ANY OF THE GLASS FRAME RETAINING SCREWS ARE LOOSE OR MISSING.**

- 7.15 Replace the lower trim to cover the gap at the bottom of the window. The louvres point forwards.  
7.16 Replace the 2 magnetic side trims.

**NEVER OPERATE THE APPLIANCE WHEN THE GLASS FRAME IS REMOVED OR BROKEN.**

**NOTE: ENSURE THAT THE LOGS ARE POSITIONED CORRECTLY, SEE SECTION 8. ONLY USE THE CORRECT AMOUNT OF LOGS AS SPECIFIED IN THE DIAGRAMS.**

## Advice on handling and disposal of fire ceramics



The side panels in this appliance are made from Refractory Ceramic Fibre (RCF), a material which is commonly used for this application.

Protective clothing is not required when handling these articles, but we recommend you follow normal hygiene rules of not smoking, eating or drinking in the work area and always wash your hands before eating or drinking.

To ensure that the release of RCF fibres are kept to a minimum, during installation and servicing a HEPA filtered vacuum is recommended to remove any dust accumulated in and around the appliance before and after working on it. When servicing the appliance it is recommended that the replaced items are not broken up, but are sealed within heavy duty polythene bags and labelled as RCF waste.

RCF waste is classed as stable, non-reactive hazardous waste and may be disposed of at a licensed landfill site.

Excessive exposure to these materials may cause temporary irritation to eyes, skin and respiratory tract; wash hands thoroughly after handling the material.

# User Instructions

## 8. Arrangement of Fuel Bed Components

**LOGS MUST BE POSITIONED ACCORDING TO THE FOLLOWING INSTRUCTIONS TO GIVE THE CORRECT FLAME EFFECT.**

- 8.1 Ensure the burner tray is clean and free from any debris.
- 8.2 The logs for the fuel bed are clearly individually labelled, see Diagram 18.

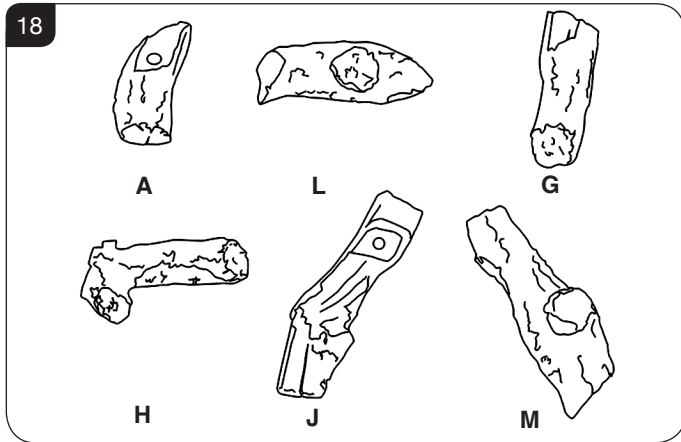

- 8.3 Place log A on the left hand front of the burner. The log will fit over the raised stud and into the groove in the burner tray, see Diagram 19.

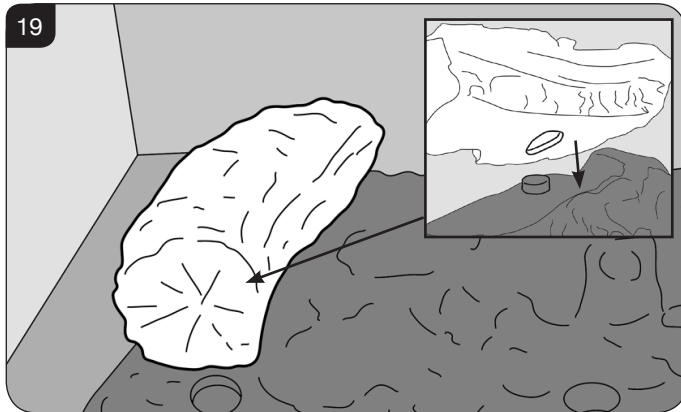

- 8.4 Place Log L behind the Log A on the flat plain and locate the rear of the log on the metal bracket. The log should rest between the lip of the bracket and the rear liner, see Diagram 20.

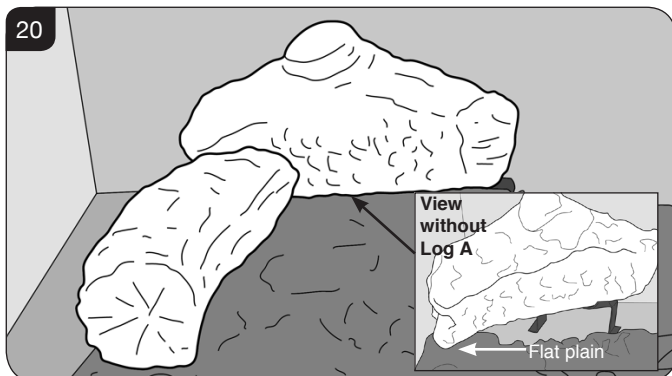

- 8.5 Place Log G on top of Log A. There is a hole on the underside of Log G which fits over the raised stud on Log A to secure in place. The end of the log sits on the raised section of the burner tray, see Diagram 21.

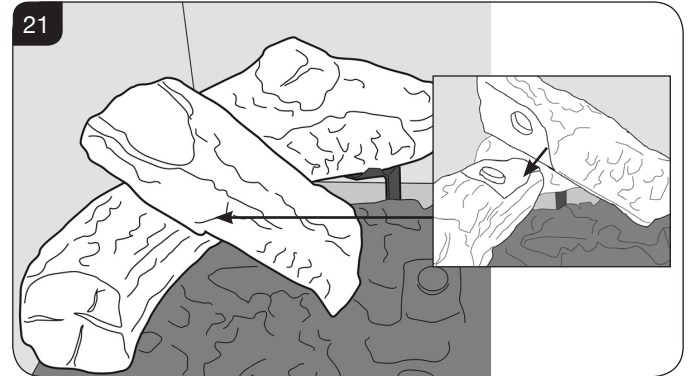

- 8.6 Place Log H on the centre of the burner tray. There is a raised stud in the fuel bed which securely locates the log in place. The right hand side rests on the raised section at the end of the air cutout, see Diagram 22.

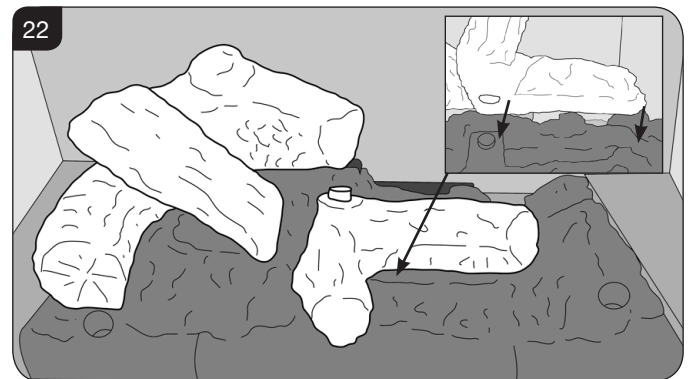

- 8.7 Rest Log J on the raised stud on Log H. The rear of the effect should rest on the metal bracket at the back of the burner tray, see Diagram 23.

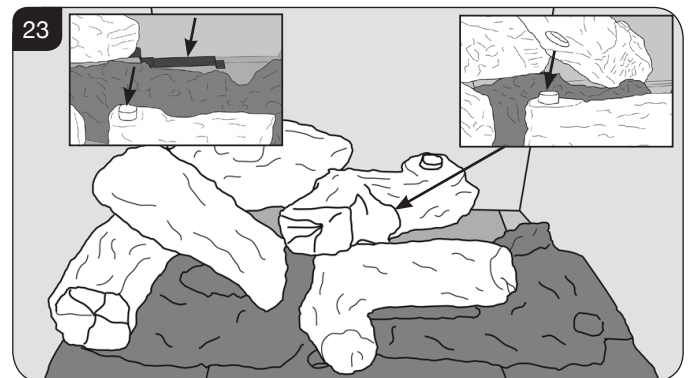

# User Instructions

- 8.8 Sit the first hole in the bottom of the left hand side of Log M on the stud of Log H and secure by fitting the middle hole on the right hand side over the stud in the fuel bed by the burner port, see Diagram 24.

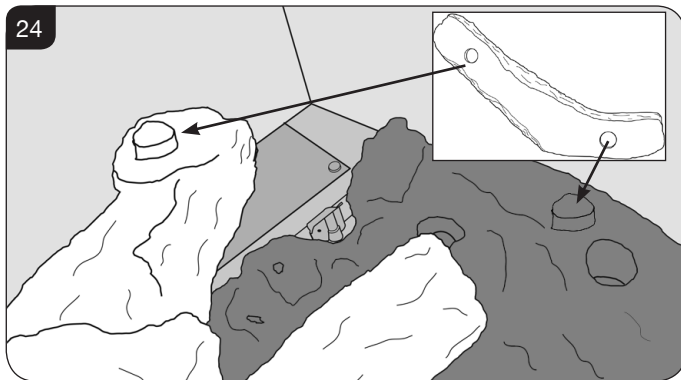

- 8.9 Log M should rest on the flat plain behind the stud for the Log arrangement to be complete, see Diagram 25.

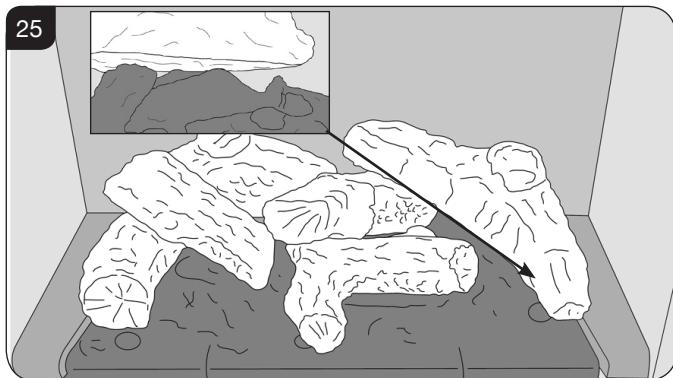

- 8.10 Place the small pieces of bark down either side, see Diagram 26.

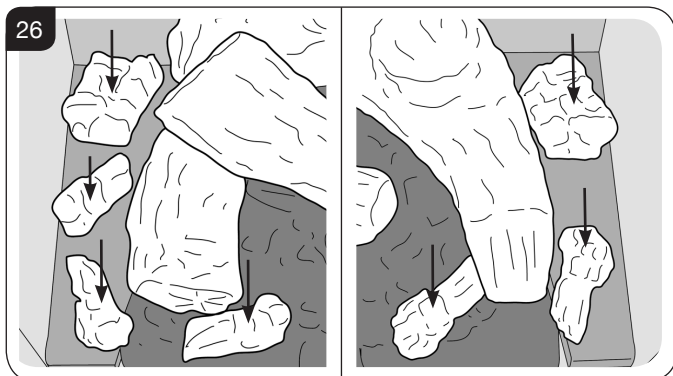

- 8.11 Lay emberglow over the small ports in the base of the burner tray. This will create a glowing effect when the appliance is lit, see Diagram 27.

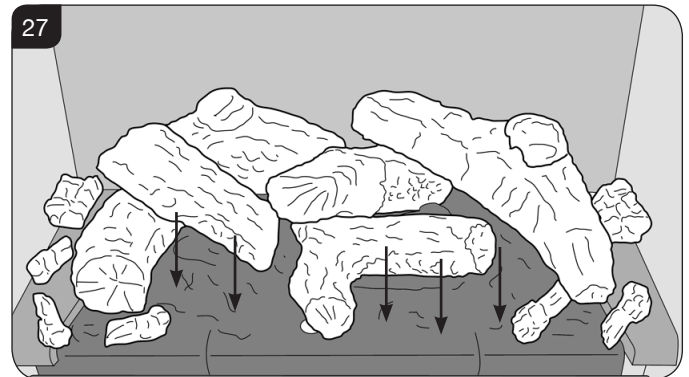

**NOTE: ENSURE THAT THE LOGS ARE POSITIONED AS ABOVE. ONLY USE THE CORRECT AMOUNT OF LOGS AS SPECIFIED IN THE DIAGRAMS.**

## 9. Flame Failure Device

- 9.1 This is a safety feature incorporated on this appliance which automatically switches off the gas supply if the pilot goes out and fails to heat the thermocouple.

**IF THIS OCCURS DO NOT ATTEMPT TO RELIGHT THE APPLIANCE FOR 3 MINUTES.**

## 10. Running In

- 10.1 During initial use of a new Gazco appliance a strong odour will be encountered as various surface coatings become hot for the first time. Although these odours are harmless it is recommended that the appliance is operated on maximum for 4 to 8 hours in order to fully burn off these coatings. After this period the odours should then disappear.

If the odours persists, please contact your installer for advice.

- 10.2 During the first few hours of burning there may be discolouration of the flames. This will also disappear after a short period of use.

## 11. Servicing

- 11.1 The appliance must be serviced every 12 months by a qualified Gas Engineer. In all correspondence always quote the Model number and the Serial number which may be found on the data badge.

## 12. Ventilation

- 12.1 This appliance requires no additional ventilation.

## 13. Installation Details

- 13.1 Your installer should have completed the commissioning sheet at the front of this book. This records the essential installation details of the appliance. In all correspondence always quote the Model number and Serial number.

# User Instructions

## 14. Hot Surfaces

- 14.1 Parts of this appliance become hot during normal use.
- 14.2 Regard all parts of the appliance as a working surface.
- 14.3 Provide a suitable fire guard to protect young children and the infirm.

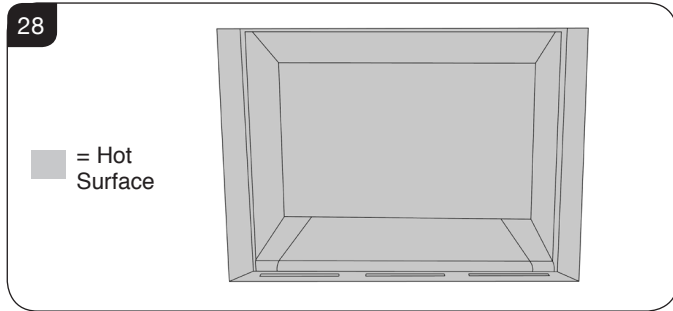

## 15. Appliance will not light

If you cannot light the appliance:

- 15.1 Check and change the batteries in the remote handset.
- 15.2 Check and change the wall touchpad batteries (see Section 6).
- 15.3 Consult your Gazco retailer or installer if the Riva2 500 still does not light.

# Installation Instructions

## Technical Specification

Covering the following models:

Riva2 500 Nat Gas	Riva2 500 LPG
134-249	134-401

Model	Gas CAT.	Gas Type	Working Pressure	Aeration	Injector	Gas Rate m <sup>3</sup> /h	Input kW (Gross)		Country
							High	Low	
Riva2 500	I <sub>2</sub> H	Natural (G20)	20mbar	2 x 7.5mm Ø	375	0.552	5.8	2.9	GB, IE
Riva2 500	I <sub>3</sub> P	Propane (G31)	37mbar	2 x 16mm Ø	125	0.211	5.6	2.9	GB, IE
<b>Efficiency Class 2 - 82% / NO<sub>x</sub> Class 3</b>									
Flue Outlet Size Ø 100mm									
Flue Inlet Size Ø 152mm Ø									
Gas Inlet Connection Size Ø 8mm									

**i** The net efficiency of this appliance has been measured as specified in EN613:2001 and the result after conversion to gross using the appropriate factor from Table E4 of SAP 2009 is 73.9%. The test data has been certified by Kiwa Nederland BV. The gross efficiency value may be used in the UK Government's Standard Assessment Procedure (SAP) for energy rating of dwellings.

### RESTRICTOR REQUIREMENT - VERTICAL & HORIZONTAL FLUE SPECIFICATION

Riva2 500		
Vertical flue height from top of appliance	Horizontal length	Restrictor size
500mm - 1000mm	Up to 500mm	N/A
1000mm - 1490mm	Up to 1000mm	N/A
1500mm - 2490mm	Up to 5000mm	70mm
2500mm - 3000mm	Up to 5000mm	60mm

### TOP EXIT - VERTICAL ONLY INCLUDING OFFSET

Riva2 500	
Vertical flue height from top of appliance	Restrictor size
3000mm - 6000mm	52mm
6000mm - 10000mm	47mm

# Installation Instructions

## Technical Specification

This appliance has been certified for use in countries other than those stated. To install this appliance in these countries, it is essential to obtain the translated instructions and in some cases the appliance will require modification. Contact Gazco for further information.

### PACKING CHECKLIST

Qty	Description	Fixing kit containing
1 x	Cassette and burner assembly	1 x Instruction manual
1 x	Lining Set	6 x Woodscrews
1 x	Log set (6 logs)	6 x Wall plugs
		1 x Self adhesive foam strip
		2 x AA 1.5 alkaline batteries
		3 x Size C batteries
		1 x Battery Holder
		1 x Touchpad/ Wall Plate

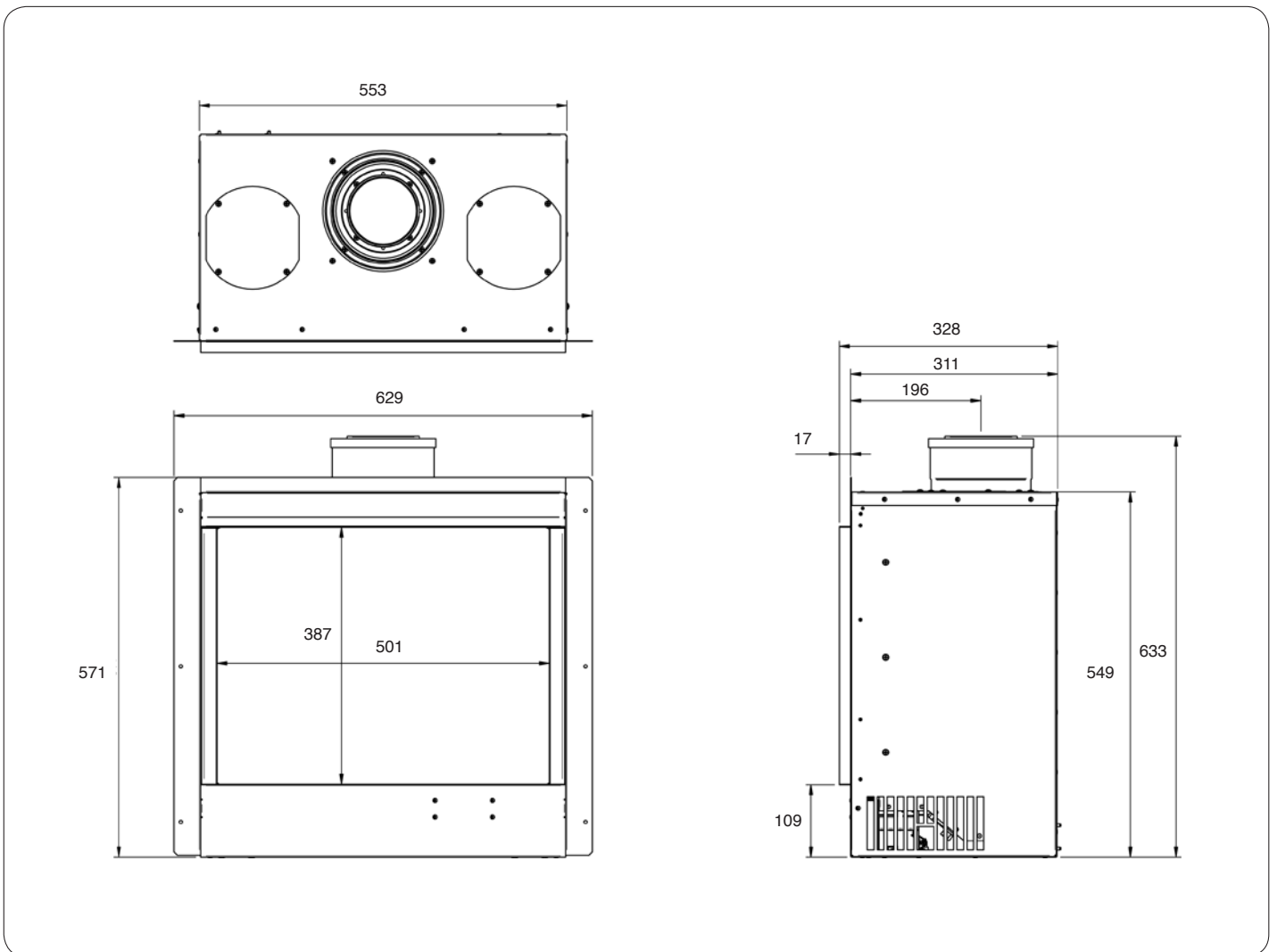



# Installation Instructions

## Site Requirements

### 1. Flue & Chimney Requirements

**NOTE: This appliance can only be installed in conjunction with the flue supplied.**

- 1.1 The flue must be sited in accordance with BS5440: Part 1 (latest edition), see Diagram 1.
- 1.2 Any terminal which is less than 2 metres above any access (level ground, balcony or above a flat roof to which people have access) is to be fitted with a guard.
- 1.3 All vertical and horizontal flues must be securely fixed and fire precautions followed in accordance with local and national codes of practice.
- 1.4 A restrictor may be required. Refer to Technical Specifications on page 15.
- 1.5 Two types of flue terminals are available, horizontal and vertical. For a horizontal terminal, decide on the terminal position and measure the height from the top of the appliance to the centre of the required hole. For minimum and maximum flue dimensions see Diagrams 2a.
- 1.6 Access must be left either above or at the side of the installation to allow the flue to be assembled on top of the appliance. When a horizontal terminal is used, the vertical sections are assembled first, then the 90-degree elbow and finally the horizontal section including the terminal. If a masonry installation is to be built, a suitable lintel must be used to support the opening.
- 1.7 Only the horizontal terminal section can be reduced in size.

1

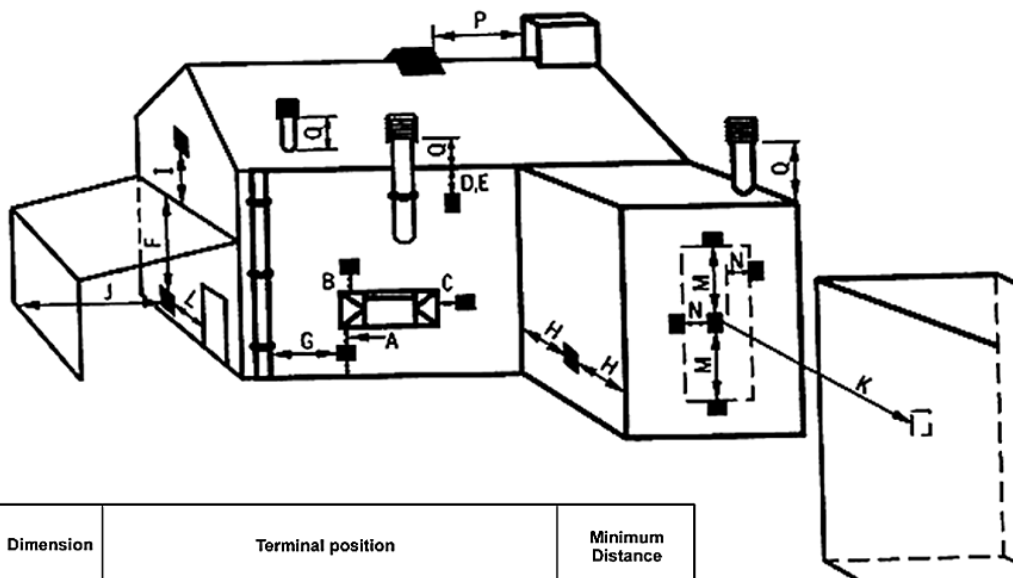

Dimension	Terminal position	Minimum Distance
A*	Directly below an opening, air brick, opening windows, etc.	600mm
B*	Above an opening, air brick opening windows, etc.	300mm
C*	Horizontally to an opening, air brick opening windows etc.	400mm
D	Below gutters, soil pipes or drain pipe	300mm
E	Below eaves	300mm
F	Below balconies or car port roof	600mm
G	From a vertical drain pipe or soil pipe	300mm
H	From an internal or external corner	600mm
I	Above group roof or balcony level	300mm
J	From a surface facing the terminal (also see 6.1.2)	600mm
K	From a terminal facing the terminal	600mm
L	From an opening in the car port (e.g. door, window) into the dwelling	1200mm
M	Vertically from a terminal on the same wall	1500mm
N	Horizontally from a terminal on the same wall	300mm
O	From the wall on which the terminal is mounted	N/A
P	From a vertical structure on the roof	600mm
Q	Above intersection with roof	300mm

\* In addition, the terminal should not be nearer than 300mm to an opening in the building fabric formed for the purpose of accommodating a built-in element such as a window frame

# Installation Instructions

## Site Requirements

### 2. Flue Options

2a

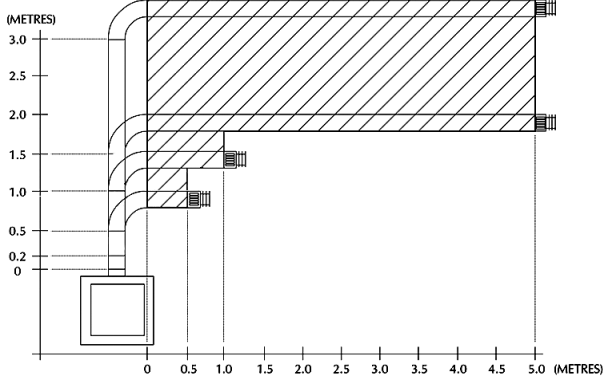

Start of bend to centre line of horizontal flue 170mm. Centre line of vertical flue to end of bend 220mm.

#### 2A. Top Flue Up and Out Kit 8509/ 8509AN

2.1 Vertical from the top of the appliance then horizontally out, see Diagram 2a. The basic kit comprises:

- 1 x 500mm terminal length
- 1 x 200mm vertical length
- 1 x 90 degree elbow
- 1 x 500mm vertical length
- 1 x wall plate
- 1 x 60mm restrictor
- 1 x 70mm restrictor
- 1 x 75mm restrictor
- 4 x fixing screw

This kit provides the minimum materials. Extra lengths can be added to the vertical and horizontal sections; see Section 3.

Refer to Installation Instructions, Technical Specification on page 16 to identify when to use a restrictor.

### 2B. Top Flue Up and Out with Additional Bend

2.2 Any additional bend may be used on the horizontal section (either 45° or 90°), but the overall horizontal flue run will be reduced. Refer to Diagram 2b.

2b

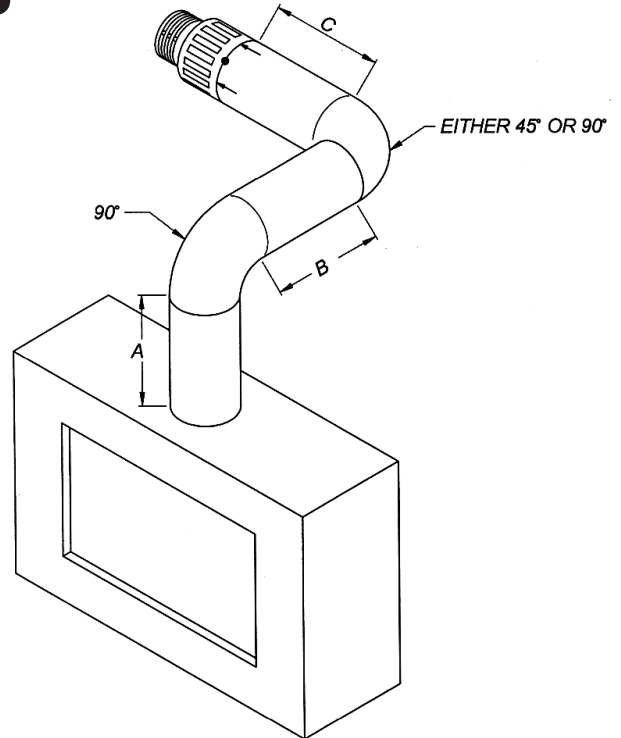

When A = 1.0 to 1.499 metres  
B & C = 1.0 metres maximum

When A = 1.499 to 3.0 metres  
B & C = 4.0 metres maximum

#### 2C Top Flue Vertical Kit (8524/8524AN)

2.3 Vertical from the top of the appliance, see Diagram 2c. A minimum vertical rise 3m (9'10") to a maximum 10m (32'10"). The basic kit comprises:

- 2 x 1m lengths
- 1 x 1m terminal length
- 1 x 70mm restrictor
- 1 x 60mm restrictor
- 1 x 52mm restrictor
- 1 x 47mm restrictor

Extra lengths may be added from the table in Section 3.

# Installation Instructions

## Site Requirements

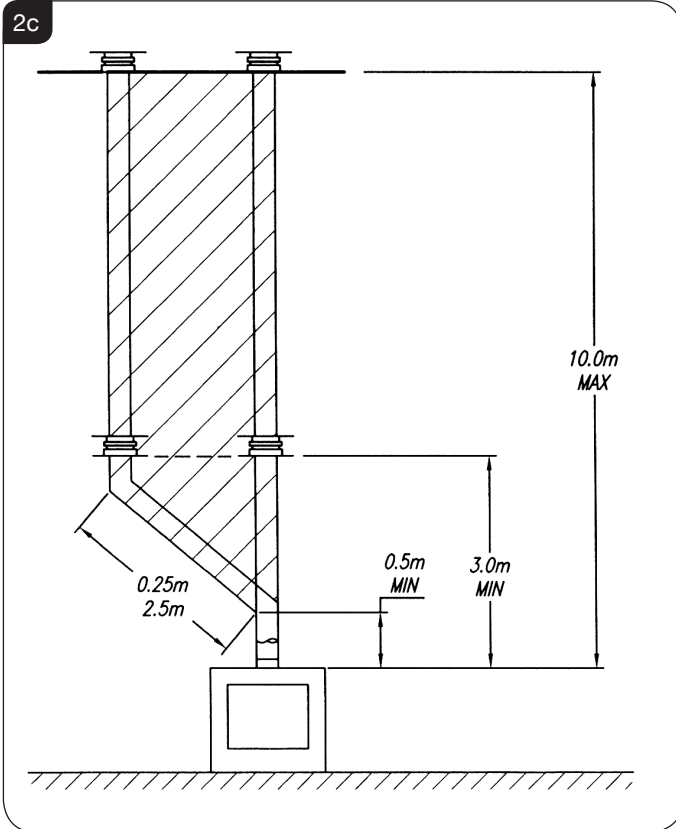

### 2D Top Flue Vertical Offset Kit (8530/8530AN)

- 2.4 Used with kit 8524. A minimum rise of 500mm (19 1/2") is required to the first bend, see Diagram 2c.

### 3. Optional Extra Flue Lengths and Bends

All flue components are 150mm diameter (6")

NOMINAL LENGTH	ACTUAL LENGTH	STAINLESS FINISH	ANTHRACITE FINISH
200mm	140mm	8527	8527AN
500mm	440mm	8528	8528AN
1000mm	940mm	8529	8529AN
40° Bend	N/A	8507	8507AN
90° Bend	N/A	8508	8508AN

NOTE: The following areas need careful consideration.

- Terminal positions
- Flue supports
- Weatherproofing
- Fire precautions

For all the above options, local and national codes of practice must be adhered to.

## 4. Gas Supply

- Before installation, ensure that the local distribution conditions (identification of the type of gas and pressure) and the adjustment of the appliance are compatible.
- Ensure that the gas supply is capable of delivering the required amount of gas and is in accordance with the rules in force.
- Soft copper tubing can be used to install the appliance. Soft soldered joints can be used externally of the appliance but must be restricted to the area shown in Diagram 3.

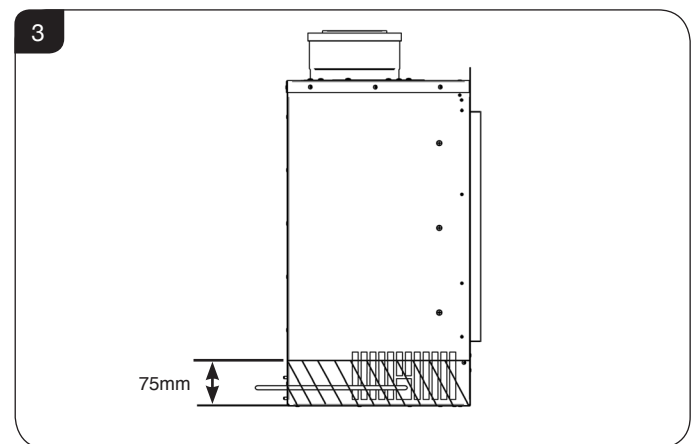

- This appliance is supplied complete with a factory fitted isolation device incorporated into the inlet connection, no further isolation device is required.
- All supply gas pipes must be purged of any debris that may have entered, prior to connection to the appliance.
- The gas supply enters through the opening located on the LEFT-HAND side of the outer box.
- The gas supply must be installed in a way that does not restrict the removal of the appliance for servicing and inspection.

## 5. Ventilation

- This appliance requires no additional ventilation.

## 6. Appliance Location



**IMPORTANT:** This appliance is supplied as an edge installation but it is possible to fit a frame (ELLINGHAM FRONT NOT INCLUDED) at a later stage without any remedial building work needed. However the base of the appliance must originally be installed a minimum of 150mm above floor level to allow for this.

# Installation Instructions

## Site Requirements

6.1 The minimum opening dimensions are shown in Diagram 4.

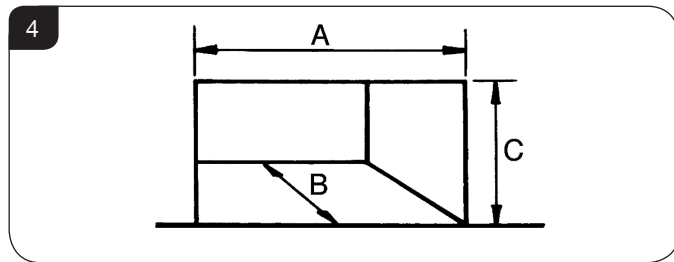

DIMENSION	Riva2 500
A	565
B	350
C	560

6.2 **NOTE: If this appliance is fitted less than 150mm from the floor then it will require a hearth to protect the floor. It should have minimum dimensions of 12mm thick projecting 300mm in front and 150mm either side of the appliance.**

This appliance must not be installed in a room that contains a bath or shower.

6.3 **NOTE: If using natural materials for the back panel of the fireplace, it is recommended that it is constructed from three or more sections to prevent cracking. Resin-based materials may not be suitable. This appliance is an effective heat producer and attention must be paid to the construction and finish of the fireplace.**

6.4 This appliance is not suitable for installation onto a combustible wall; all combustible materials must be removed from the area shown in Diagrams 5.

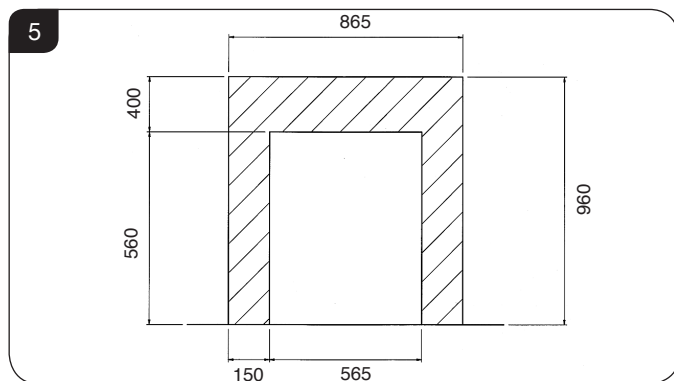

## STUDWORK INSTALLATION

6.5 If a studwork installation is used (eg. wooden framework and plasterboard), combustible parts of the studwork must not be any closer than the minimum dimensions shown in the diagrams. **NOTE:** These dimensions must be maintained even if the combustible materials is protected by non-combustible linings.

6.6 Do not pack the void around or above the appliance with insulation materials such as mineral wool.

6.7 The void into which the cassette is fitted must be ventilated to prevent a build up of heat. If the void is sealed then it will be necessary to fit vents at both low and high levels of approximately 50cm<sup>2</sup> each. These vents should take cold air from the room and return warm air back into the room.

6.8 A removable access hatch must be left in the side of the chimney breast for future servicing and inspection of the appliance.

6.9 Build the studwork chimney breast to the desired size. Ensure that the clearances to combustible materials is maintained.

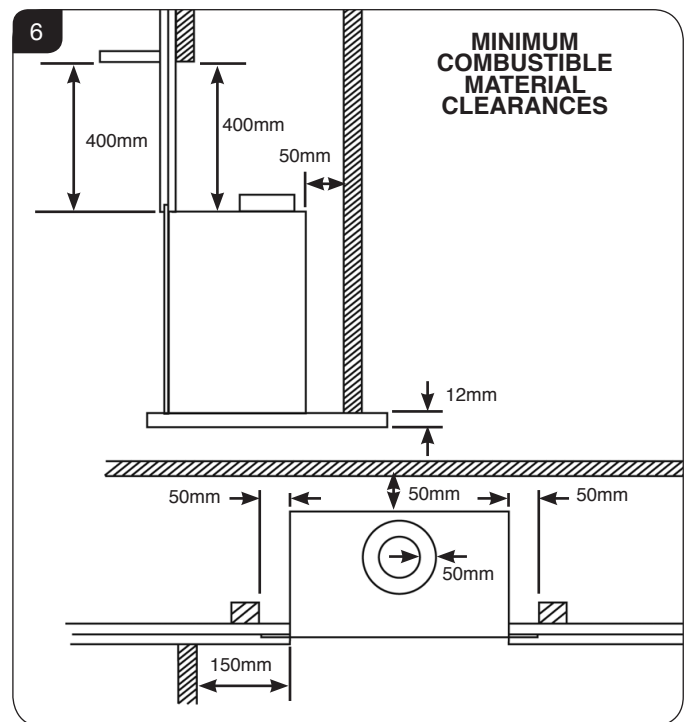

It is recommended that a marble slip or similar material is used when fitting cassette fireplaces into a plastered surface, in order to allow for heat dissipation. Also allow adequate time for newly plastered areas to dry out. Rapid drying can create cracks. If in doubt, seek the advice of a professional plasterer.

Parts of this appliance become hot during normal use. It is therefore recommended that a suitable fire guard be used for protection of young children and the infirm.

# Installation Instructions

## 1. Safety Precautions

- 1.1 For your own and other's safety, you must install this appliance according to local and national codes of practice. Failure to install the appliance correctly could lead to prosecution. **Read these instructions before installing and using this appliance.**
- 1.2 These instructions must be left intact with the user.
- 1.3 Do not attempt to burn rubbish on this appliance.
- 1.4 Keep all plastic bags away from young children.
- 1.5 Do not place any object on or near to the appliance and allow adequate clearance above the appliance.

**IF THE APPLIANCE IS EXTINGUISHED OR GOES OUT IN USE, WAIT 3 MINUTES BEFORE ATTEMPTING TO RELIGHT THE APPLIANCE.**



**IMPORTANT: REFER TO DATA BADGE AND TECHNICAL SPECIFICATION AT THE FRONT OF THE MANUAL TO ENSURE THE APPLIANCE IS CORRECTLY ADJUSTED FOR THE GAS TYPE AND CATEGORY APPLICABLE IN THE COUNTRY OF USE.**

**FOR DETAILS OF CHANGING BETWEEN GAS TYPES REFER TO SERVICING, SECTION 12, REPLACING PARTS.**

## Unpacking

- 1.6 Remove the appliance from its packaging, and check that it is complete and undamaged.

Put the loose ceramic parts to one side so that they are not damaged during installation.

## 2. Installation of the Appliance

- 2.1 There are 2 methods of installation:

1) Edge, Verve XS and Icon frames, see Section 5A.



**EDGE, VERVE XS AND ICON FRAMES ONLY: IMPORTANT: NO MATTER IF A FRAME IS TO BE ATTACHED OR NOT, FOR THIS METHOD THE APPLIANCE MUST ALWAYS BE INSTALLED AS AN EDGE FINISH REGARDLESS OF WHETHER IT IS FITTED INTO A MASONRY OR STUDWORK SETTING.**

2) Ellingham Front, see Section 5B.



**IMPORTANT: THE METHOD OF INSTALLATION IS DIFFERENT WHEN INSTALLING AN ELLINGHAM FRONT AND DOES NOT REQUIRE AN EDGE FINISH.**

- 2.2 **THE APPLIANCE IS SUPPLIED WITH A WALL BOX CONTAINING THE BATTERIES AND TOUCH PAD. THIS MUST BE RECESSED INTO THE WALL WITH ACCESS FOR THE CABLES PRIOR TO FITTING THE APPLIANCE.**

## 3. Removing the Glass Frame

- 3.1 Remove the glass frame by removing the 2 side trims, see Diagram 1. These are held on by magnets.

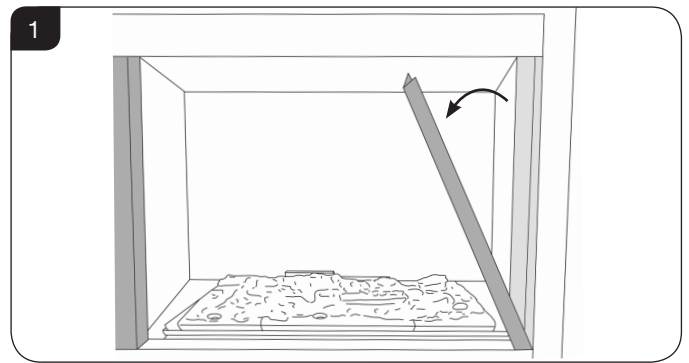

- 3.2 Lift out the bottom slotted trim, see Diagram 2. Note the orientation of the metal shield for reassembly.

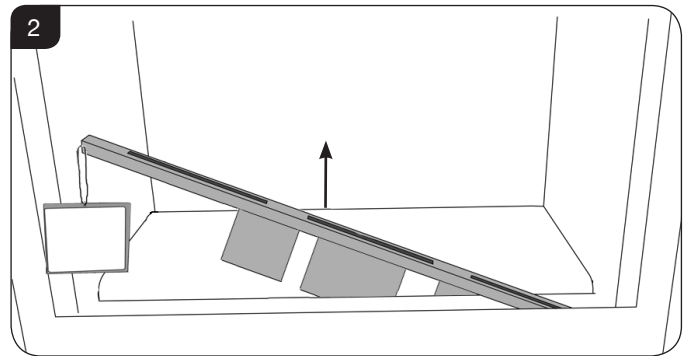

- 3.3 Remove the 2 screws at the base of the glass frame, see Diagram 3.

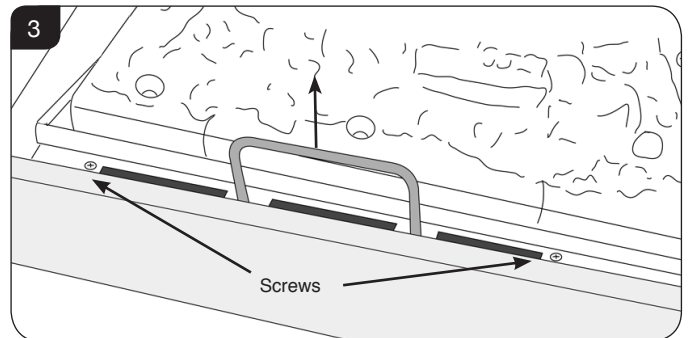

- 3.4 Pull up the handle at the front, see Diagram 3.

# Installation Instructions

- 3.5 Whilst supporting the top, lift the glass frame using the handle, up and over the lower edge, see Diagram 4.

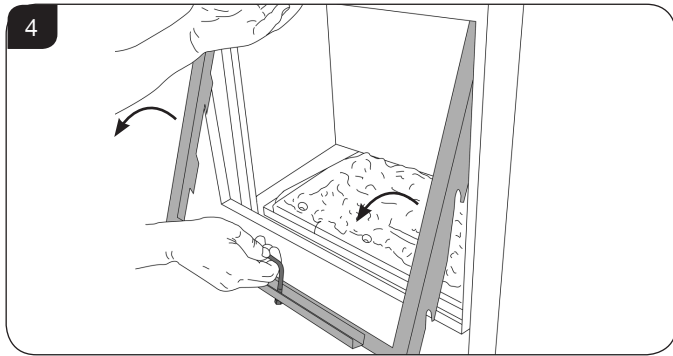

- 3.6 Remove the 2 screws at the front of the burner unit, see Diagram 6.

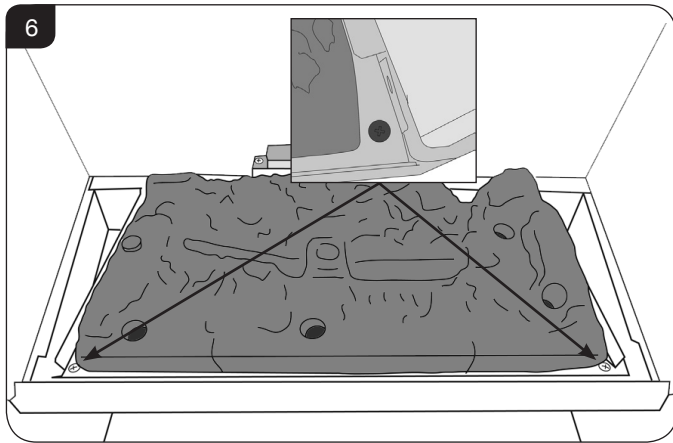

- 3.7 Slide the burner unit to the right, pull slightly forward and lift from the back. Carefully remove through the front of the appliance. Place carefully to one side.

Note: When reinstalling the burner unit ensure that the tabs at the back of the burner tray engage in the channel under the back panel.

- 3.8 Remove the 4 screws to remove the access plate.

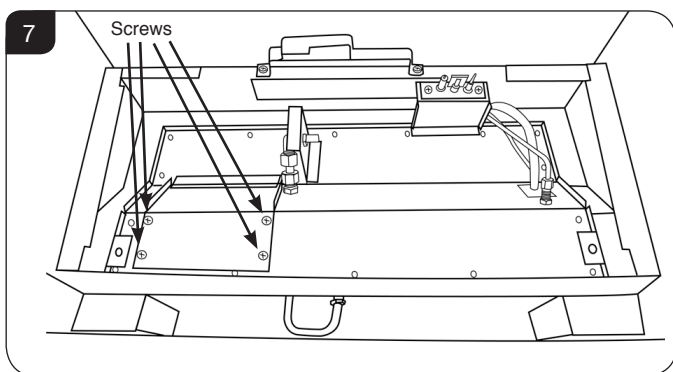

- 3.9 The gas supply enters through the opening located on the left-hand side of the outer box, see Diagram 8.

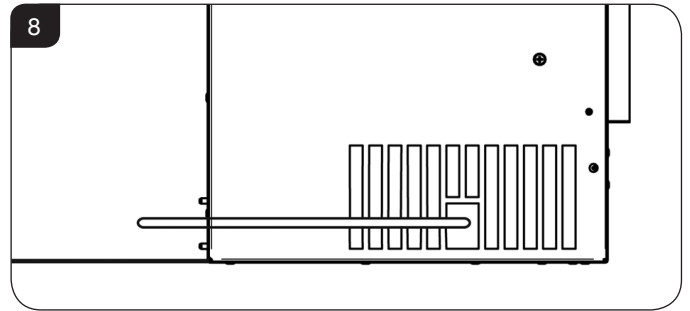

Note: The isolation elbow needs to be attached to the gas pipe before installation.

## 4. All types of Installation - Wall Box & Batteries



Please note: As an optional extra Gazco can provide a mains adapter to supply constant power to the appliance control box instead of the battery pack.

If installing an appliance with the adapter make provision for a mains power socket within 1.5m of the control box and follow the instructions provided.

- 4.1 Decide on the position for the wall box containing the batteries and wall switch.

### NOTE:

A combined battery power supply and touch control cable is supplied and pre-fitted to the appliance control. Provision is made for the cable to exit either the left of the appliance through the grommet or the silicon panel at the back. The cable is 3 metres long.

When deciding the route of the cables consideration must be given to avoiding contact with the appliance and the flue system.

- 4.2 Correctly position the three new high quality (Duracell or similar) size C batteries into the battery holder. Replace the cover by sliding it on to the battery holder.

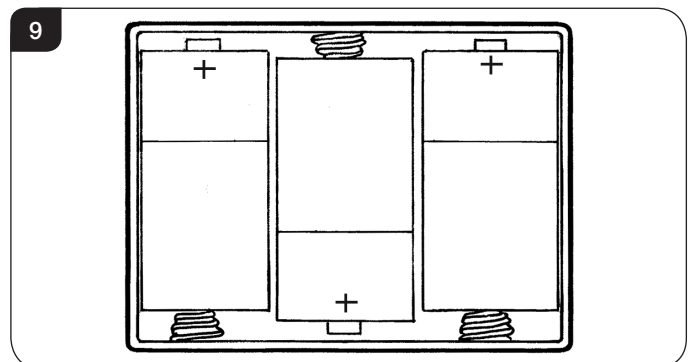

- 4.3 Slide the battery box into its housing in the back of the wall plate, see Diagram 10.

# Installation Instructions

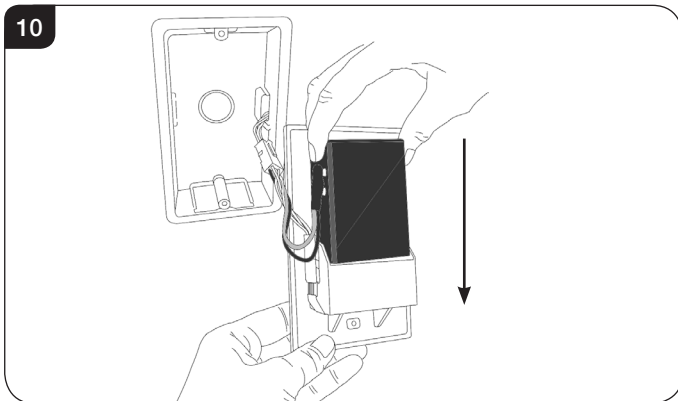

4.4 Ensure both sets of wires are connected, see Diagrams 11 & 12. When replacing the 4 pronged connector ensure that the arrows are aligned.

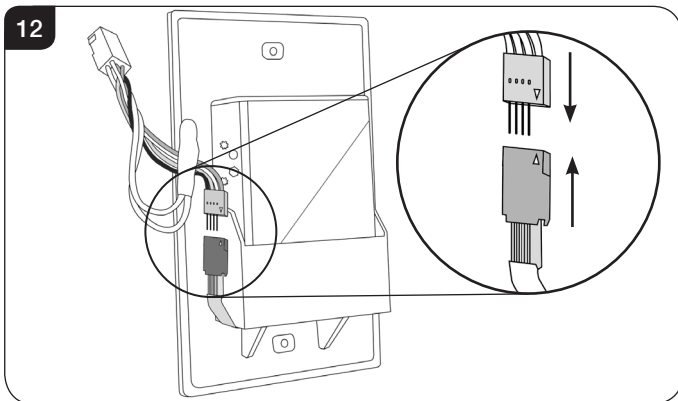
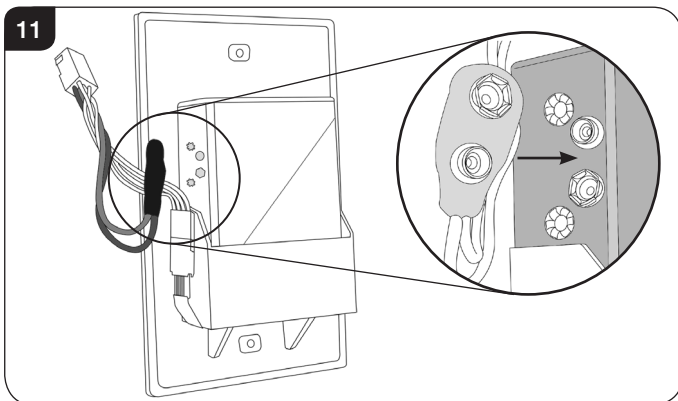

4.5 Connect the cable from the appliance to the touch pad cable, see Diagram 13.

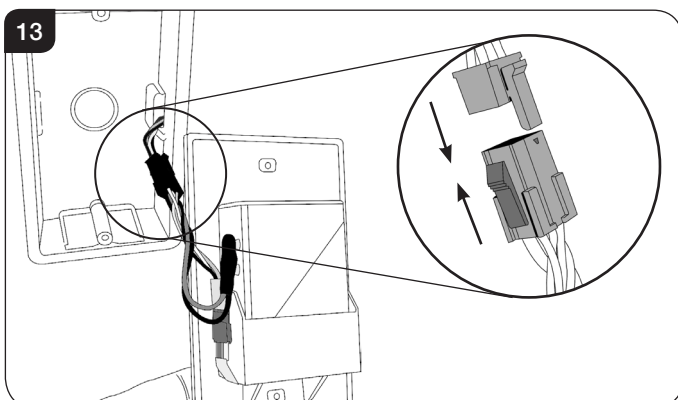

4.6 **IMPORTANT: THE WALL SWITCH MUST BE INSTALLED USING THE PLASTIC DRY LINING BOX SUPPLIED.**

Secure the wall plate to the dry lining box with the 2 x screws provided, see Diagram 14.

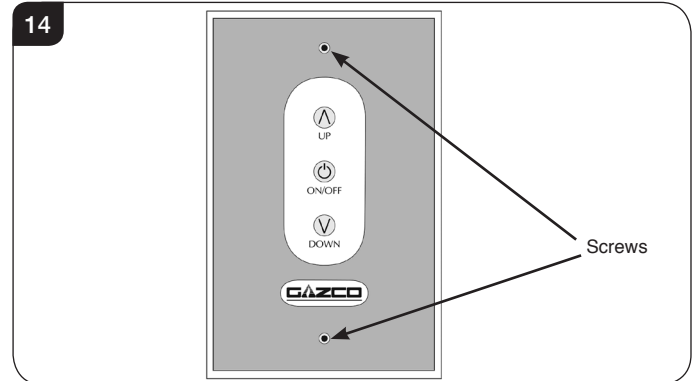

**PLEASE ENSURE NO WIRES ARE TRAPPED BEFORE REPLACING THE WALL PLATE. THE TOUCH PAD LEAD IS EASILY DAMAGED.**

## 5. Studwork Installation

5.1 DISTANCE TO COMBUSTIBLE MATERIAL

**COMBUSTIBLE PARTS OF THE STUDWORK MUST BE KEPT BEYOND THE MINIMUM DIMENSIONS SHOWN IN DIAGRAM 15. EVEN IF THE FRAMEWORK IS PROTECTED BY NON-COMBUSTIBLE MATERIAL, YOU MUST MAINTAIN THESE DIMENSIONS, SEE DIAGRAM 15.**

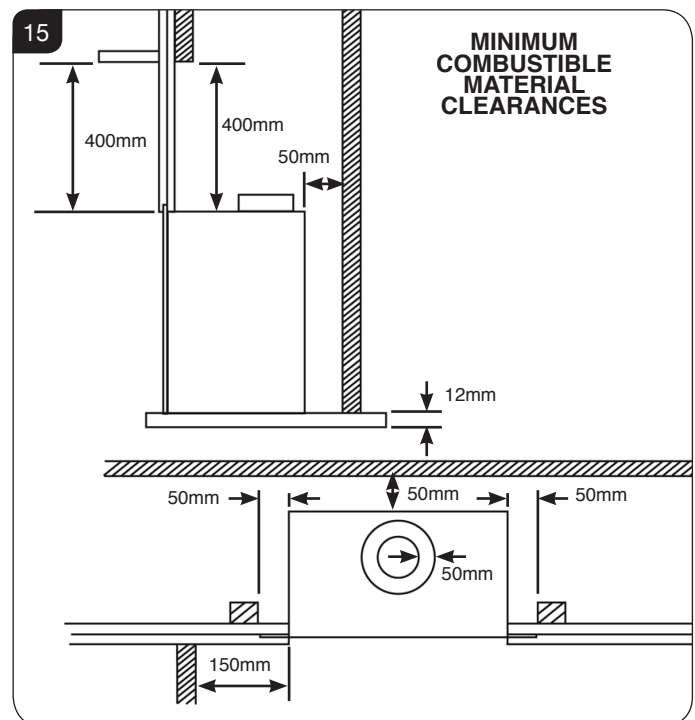

5.2 **DO NOT PACK THE VOID AROUND OR ABOVE THE APPLIANCE WITH INSULATION MATERIALS SUCH AS MINERAL WOOL.**

# Installation Instructions

- 5.3 THE VOID BUILT FOR THE CASSETTE MUST BE VENTILATED TO PREVENT A BUILD-UP OF HEAT. IF THE VOID IS SEALED, THEN YOU MUST FIT VENTS AT BOTH LOW AND HIGH LEVELS OF A MINIMUM OF 50CM<sup>2</sup> EACH. THESE VENTS MUST TAKE COLD AIR FROM THE ROOM AND RETURN WARM AIR BACK INTO THE ROOM.
- 5.4 ALTERNATIVELY FOR THE HIGH VENTILATION THE ENCLOSURE CAN BE CONSTRUCTED TO LEAVE A GAP BETWEEN THE TOP OF THE WALL AND THE CEILING GIVING THE REQUIRED VENTILATION AREA OR GREATER.
- 5.5 AN ACCESS HATCH MUST BE LEFT IN THE SIDE OF THE CHIMNEY BREAST FOR FUTURE SERVICING AND INSPECTION OF THE FLUE AND APPLIANCE.

There are 2 methods of installation:

- 1) Edge, Verve XS and Icon frames, see Section 5A.
- 2) Ellingham Front, see Section 5B.

## 5A. Edge, Verve XS, Icon



**IMPORTANT: NO MATTER IF A FRAME IS TO BE ATTACHED OR NOT, FOR THIS METHOD THE APPLIANCE MUST ALWAYS BE INSTALLED AS AN EDGE FINISH.**



**IMPORTANT: BEFORE THE INSTALLATION OF THE DECORATIVE FRAME ENSURE THAT THE WALL ABOVE AND TO THE SIDES OF THE APPLIANCE IS SUITABLY CONSTRUCTED FOR THE FIXINGS TO SUPPORT THE WEIGHT OF THE FRAME. IF THE WALL IS CONSTRUCTED FROM PLASTERBOARD OR SIMILAR, IT IS ESSENTIAL THAT BATTERNS ARE LOCATED TO THE SIDES OF THE APPLIANCE IN THE FIXING AREA TO PROVIDE STRENGTH TO THE FIXINGS. SEE DIAGRAM 16.**

- 5.6 When constructing a studwork installation it is essential to observe the clearances to combustibles but make provision for the frame fixings, see Diagram 16.

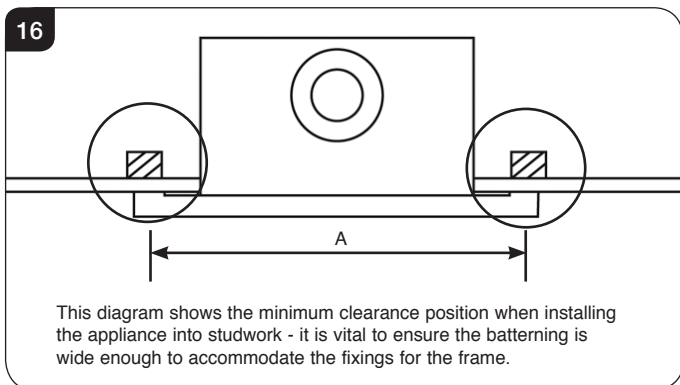

Distance between frame fixings:

FRAME OPTION	A
Verve XS	677.5
Icon	725

## Combustible Studwork

- 5.7 Build the studwork chimney breast and enclosure to the desired size to include a 12mm non-combustible platform at the required height, see Diagram 17.  
**Ensure that the clearances to combustible materials is maintained and the frame option is considered, see 5.6.**

17

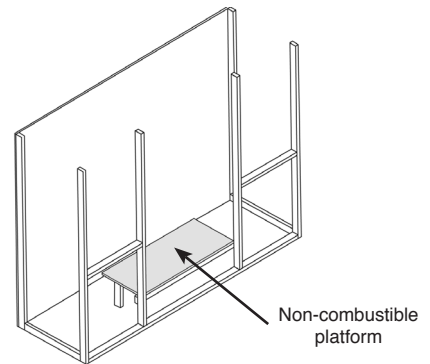

Ensure that there is an offset between the first 2 front vertical studs on either side of the aperture, see Diagram 18. This is to allow for the extra non-combustible board to be fitted to the first vertical stud, to secure the appliance flange, see 5.11.

18

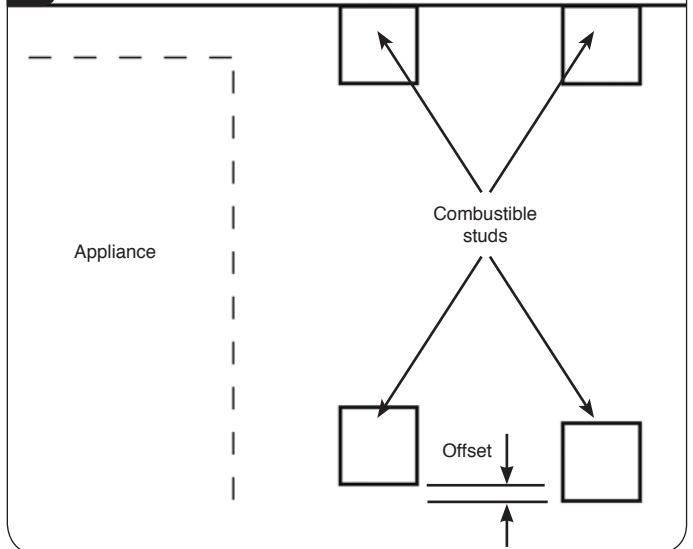

Decide upon and cut the hole for the flue exit (see Site Requirements, Section 2).

- 5.8 Provide gas and electric services into the void on the left-hand side.



# Installation Instructions

- 5.9 Before fitting the cladding, cut 2 175 x 80 mm<sup>2</sup> minimum holes in the non-combustible side boards to allow air circulation around the appliance vents, see Diagrams 19 & 20.

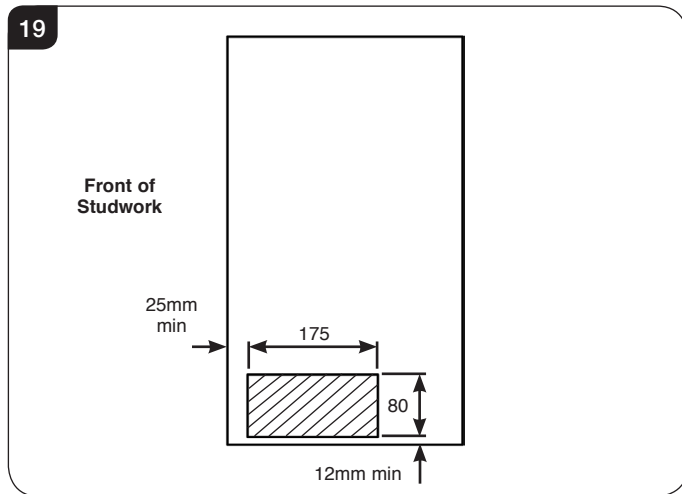

- 5.10 Line the aperture for the appliance with 12mm thick non-combustible material, see Diagram 20.

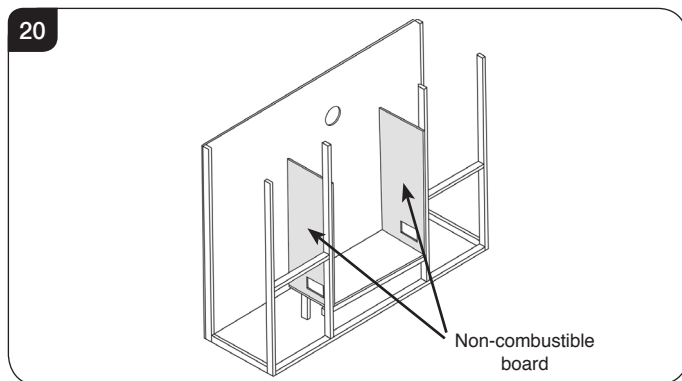

- 5.11 Fit non-combustible board to the studwork to the sides of the appliance aperture, this is to provide a surface to secure the appliance flange, see Diagram 21.

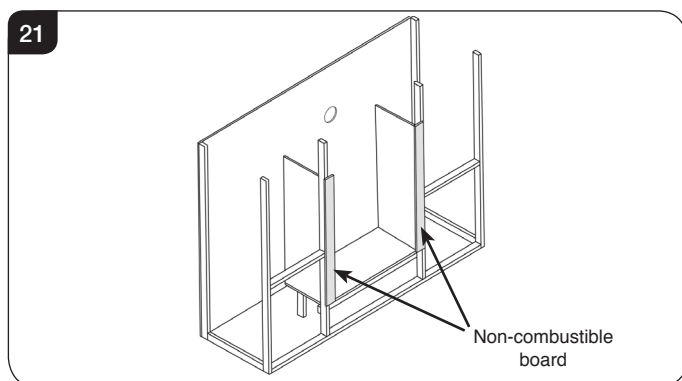

The non-combustible board should extend from the sides of the appliance casing to at least the outside edge of the studwork and to the minimum of the following dimensions:

- 400mm above.
  - To the base of the appliance.
- See Diagram 22.

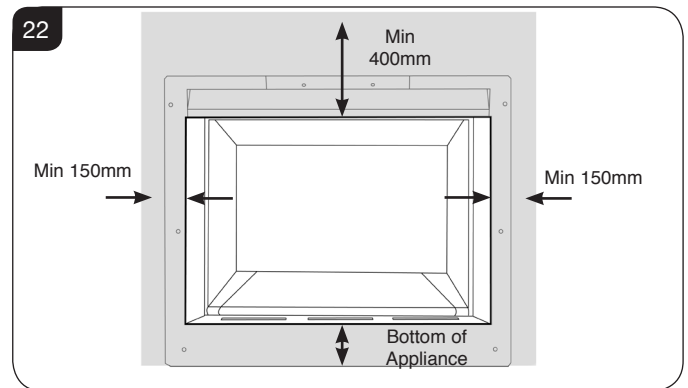

Ensure distances to combustibles are observed, see Diagram 15.

- 5.12 Fix the self adhesive foam seal around the back of the fixing flange of the appliance.
- 5.13 Place the appliance into position and secure through the 6 fixing holes, using the screws provided, see Diagram 23.

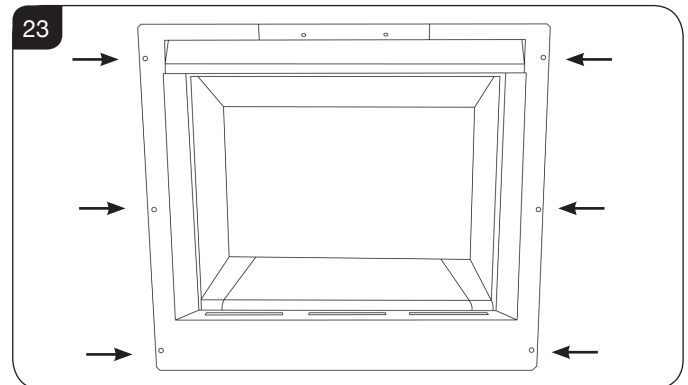

- 5.14 Connect the flue system, see Installation, Section 6.
- 5.15 Connect Gas and electrical services, see Installation, Section 7 and complete a Gas Soundness Pressure test, see Section 8.
- 5.16 Fit non-combustible board to the non-combustible board and studwork around the front of the appliance, see Diagram 24.

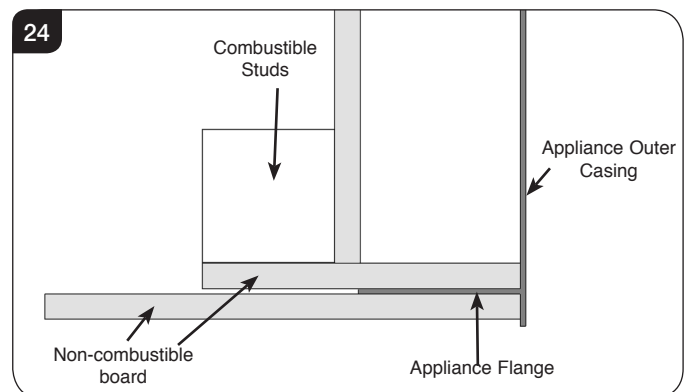

This should extend to the minimum dimensions shown in Diagram 20.

Ensure the clearances are maintained, see Diagram 15.

- 5.17 Fit plasterboard to the remainder of the chimney breast.

# Installation Instructions

- 5.18 Apply a heat resistant plaster around the appliance, see Diagram 25.

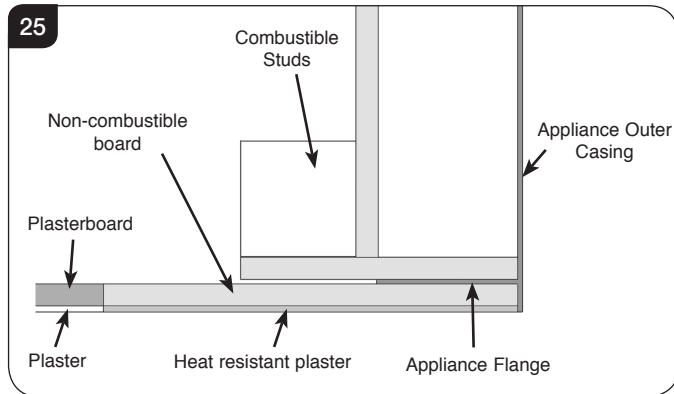

This should extend to the minimum dimensions shown in Diagram 22.

Ensure distances to combustibles are observed, see Diagram 15.

- 5.19 Apply a plaster finish to the remaining plasterboard.

To finish the installation see 5.55.

## Non-Combustible Studwork

- 5.20 Build the studwork chimney breast and enclosure to the desired size to include a 12mm non-combustible platform at the required height, see Diagram 26.  
**Ensure that the clearances to combustibles is maintained,** decide upon and cut the hole for the flue exit (see Site Requirements, Section 2).

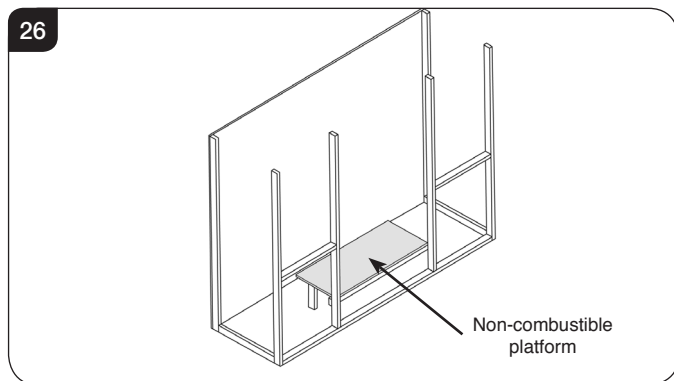

- 5.21 Provide gas and electric services into the void on the left-hand side.
- 5.22 Fix the self adhesive foam seal around the back of the fixing flange of the appliance.
- 5.23 Place the cassette into position and secure through the 6 fixing holes, using the screws provided, see Diagram 27.

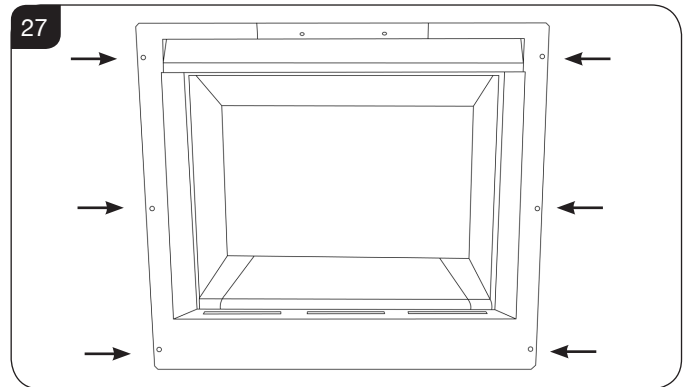

- 5.24 Connect the flue system, see Installation, Section 6.

- 5.25 Connect Gas and electrical services, see Installation, Section 7 and complete a Gas Soundness Pressure test, see Section 8.

- 5.26 Fit non-combustible board to the studwork around the front of the appliance, see Diagram 28.

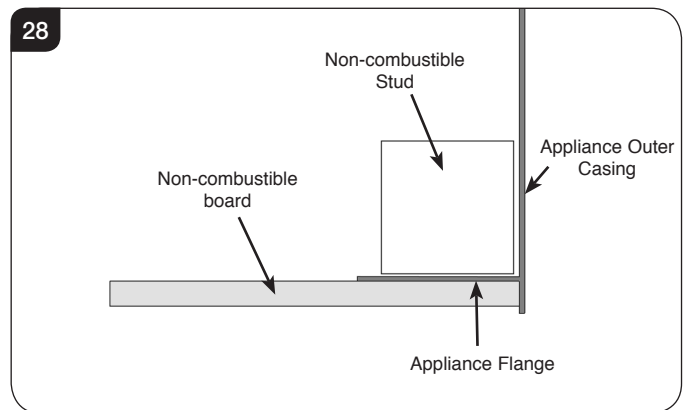

This should extend to the minimum dimensions shown in Diagram 29.

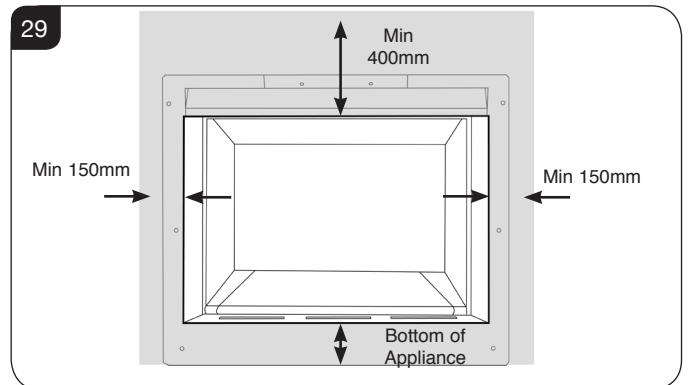

Ensure distances to combustibles are observed, see Diagram 15.

- 5.27 Fit plasterboard to the remainder of the studwork chimney.
- 5.28 Apply a heat resistant plaster around the appliance, see Diagram 30.

# Installation Instructions

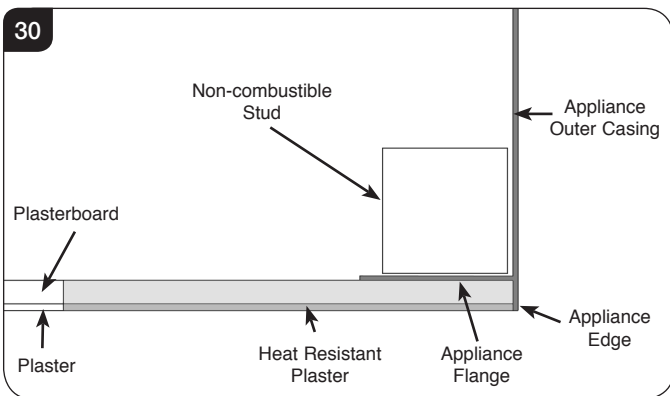

This should extend to the minimum dimensions shown in Diagram 29.

Ensure distances to combustibles are observed, see Diagram 15.

5.29 Apply a plaster finish to the remaining plasterboard.

To finish the installation see 5.55.

## 5B. Ellingham Front



**IMPORTANT: BEFORE THE INSTALLATION OF THE DECORATIVE FRONT ENSURE THAT THE WALL ABOVE AND TO THE SIDES OF THE APPLIANCE IS SUITABLY CONSTRUCTED FOR THE FIXINGS TO SUPPORT THE WEIGHT OF THE FRONT. IF THE WALL IS CONSTRUCTED FROM PLASTERBOARD OR SIMILAR, IT IS ESSENTIAL THAT BATTERNS ARE LOCATED TO THE SIDES OF THE APPLIANCE IN THE FIXING AREA TO PROVIDE STRENGTH TO THE FIXINGS. SEE DIAGRAM 30.**

When constructing a studwork installation it is essential to observe the clearances to combustibles but make provision for the frame fixings, see Diagram 31.

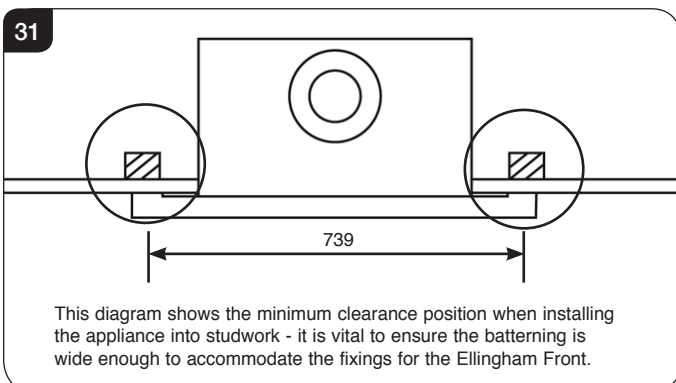

This diagram shows the minimum clearance position when installing the appliance into studwork - it is vital to ensure the battering is wide enough to accommodate the fixings for the Ellingham Front.

Distance between front fixings:

	A
Ellingham Front	739

## Combustible Studwork

5.30 Build the studwork chimney breast and enclosure to the desired size to include a 12mm non-combustible hearth, see Site requirements Section 5.

**Ensure that the clearances to combustibles is maintained, decide upon and cut the hole for the flue exit (see Site Requirements, Section 2).**

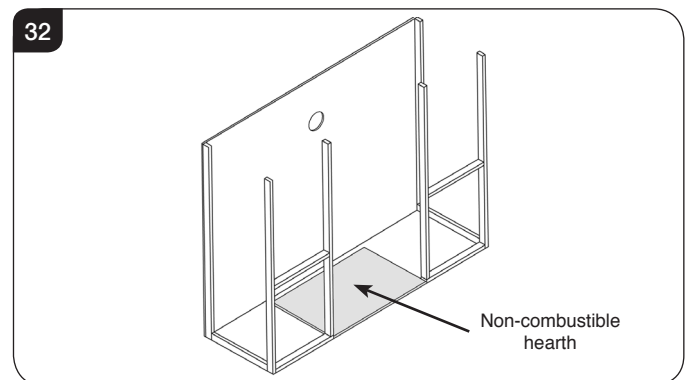

5.31 Provide gas and electric services into the void on the left-hand side.

5.32 Before fitting the cladding, cut 2 175 x 80 mm<sup>2</sup> minimum holes in the non-combustible side boards to allow air circulation around the appliance vents, see Diagrams 33 & 34.

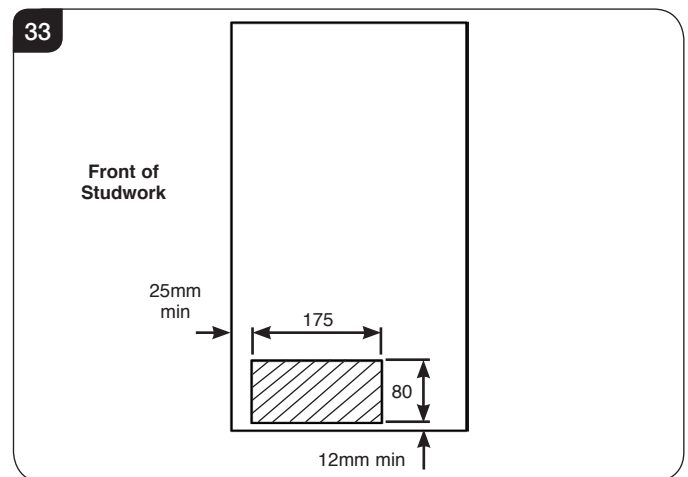

5.33 Line the aperture for the appliance with 12mm thick non-combustible material, see Diagram 34.

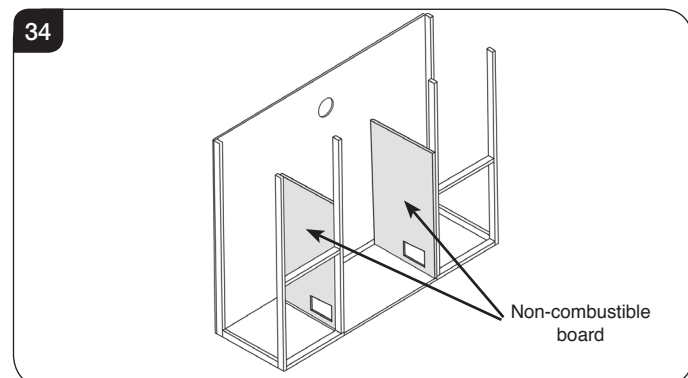

# Installation Instructions

5.34 Fit non-combustible board to the studwork to the sides of the appliance aperture, see Diagram 35.

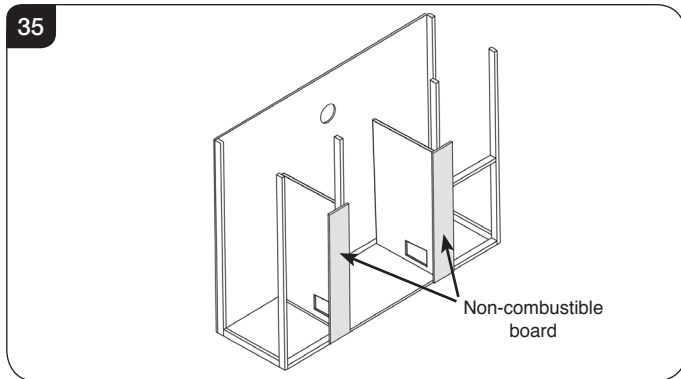

This should extend to the minimum dimensions shown in Diagram 36.

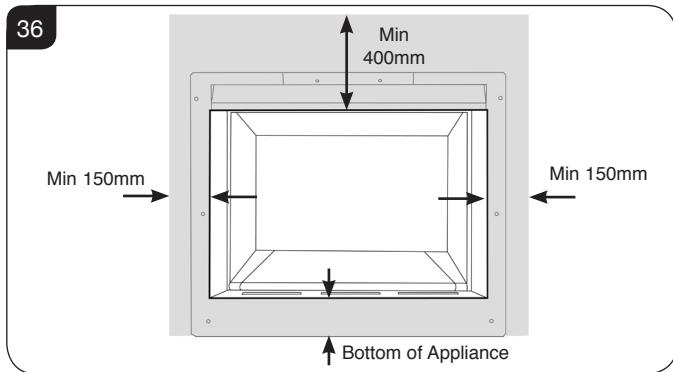

Ensure distances to combustibles are observed, see Diagram 15.

5.35 Fix the self adhesive foam seal around the back of the fixing flange of the appliance.

5.36 Place the cassette into position and secure through the 6 fixing holes, using the screws provided, see Diagram 37.

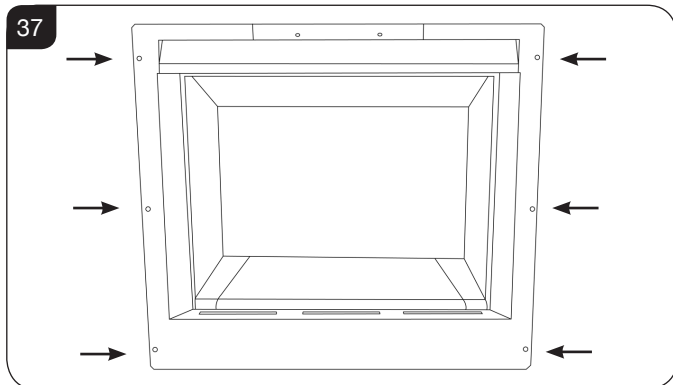

5.37 Connect the flue system, see Installation, Section 6.

5.38 Connect Gas and electrical services, see Installation, Section 7 and complete a Gas Soundness Pressure test, see Section 8.

5.39 Fit non-combustible board above the appliance. This should extend to the minimum dimensions shown in Diagram 36.

5.40 Fit plasterboard to the remainder of the studwork chimney.

5.41 Apply a heat resistant plaster around the appliance, see Diagram 38.

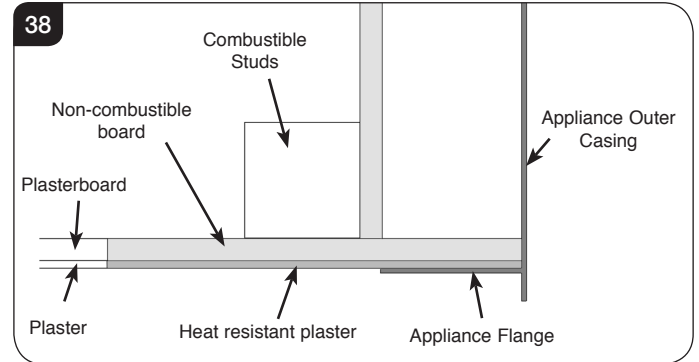

Ensure distances to combustibles are observed, see Diagram 15.

5.42 Apply a plaster finish to the remaining plasterboard.

To finish the installation see 5.55.

5.43 Install the Ellingham Front referring to separate installation instructions.

## Non-Combustible Studwork

5.44 Build the studwork chimney breast and enclosure to the desired size to include a 12mm non-combustible hearth, see Site requirements Section 5.

**Ensure that the clearances to combustible materials is maintained,** decide upon and cut the hole for the flue exit (see Site Requirements, Section 2).

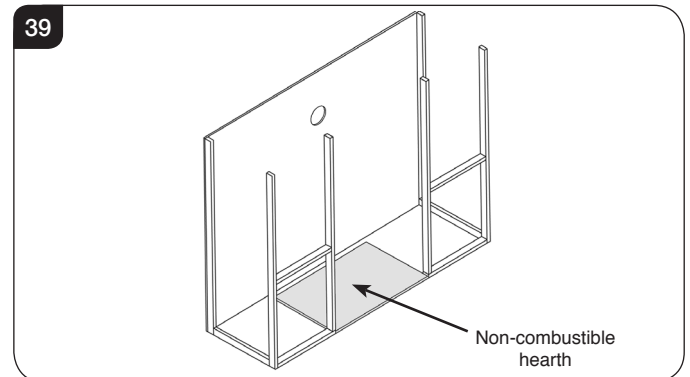

5.45 Provide gas and electric services into the void on the left-hand side.

5.46 Fit non-combustible board to the studwork to the sides of the appliance aperture, see Diagram 40.

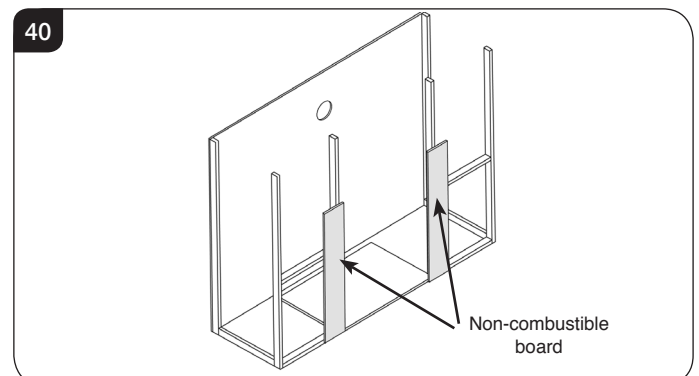

# Installation Instructions

This should extend to the minimum dimensions shown in Diagram 41.

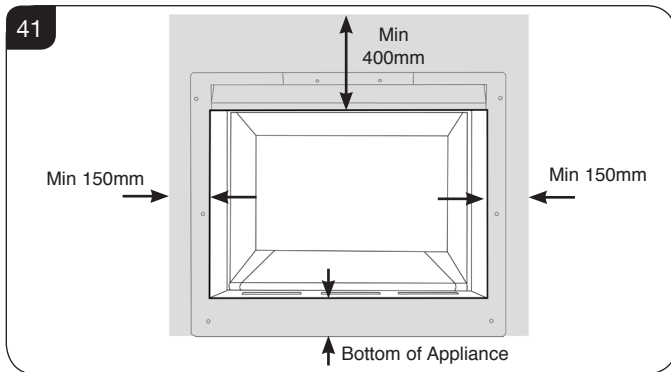

Ensure distances to combustibles are observed, see Diagram 15.

5.47 Fix the self adhesive foam seal around the back of the fixing flange of the appliance.

5.48 Place the cassette into position and secure through the 6 fixing holes, using the screws provided, see Diagram 42.

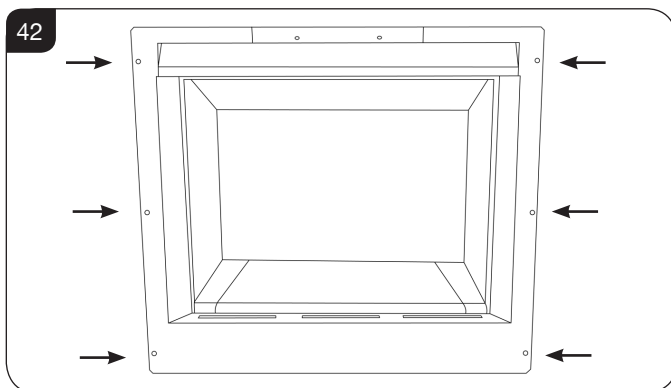

5.49 Connect the flue system, see Installation, Section 6.

5.50 Connect Gas and electrical services, see Installation, Section 7 and complete a Gas Soundness Pressure test, see Section 8.

5.51 Fit non-combustible board above the appliance. This should extend to the minimum dimensions shown in Diagram 41.

Ensure distances to combustibles are observed, see Diagram 15.

5.52 Fit plasterboard to the remainder of the studwork chimney.

5.53 Apply a heat resistant plaster around the appliance, see Diagram 43.

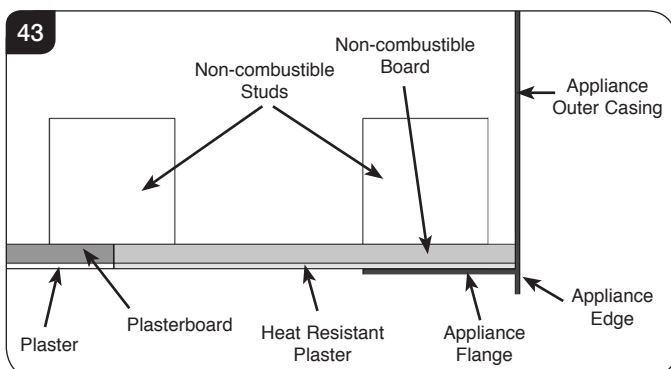

Ensure distances to combustibles are observed, see Diagram 15.

5.54 Apply a plaster finish to the remaining plasterboard.

To finish the installation see 5.55.

## To Finish the Installation

5.55 Connect the wall box and batteries following instruction in Section 4.

5.56 Connect the gas services using the opening in the side of the chimney breast for access.

### After commissioning:

5.57 Finish the sides of the chimney breast, see Diagram 44.

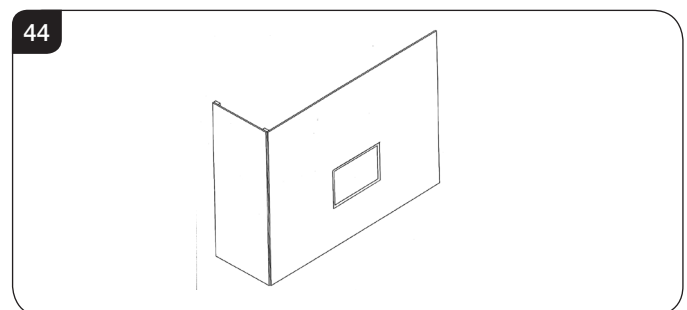

5.58 A removable access hatch must be left in the side of the chimney breast for future servicing and inspection of the appliance.

## 6. Flue Assembly

6.1 See Site Requirements, Section 2, Flue Options.

**TAKE CARE WHEN MARKING OUT FOR THE FLUE AS IT IS DIFFICULT TO MOVE AFTER INSTALLATION. IF A RESTRICTOR IS REQUIRED FIT THIS BETWEEN THE SMALL OUTLET SPIGOT AND THE AIR DUCT, SEE DIAGRAM 45. REFER TO TECHNICAL SPECIFICATIONS FOR RESTRICTOR SIZE.**

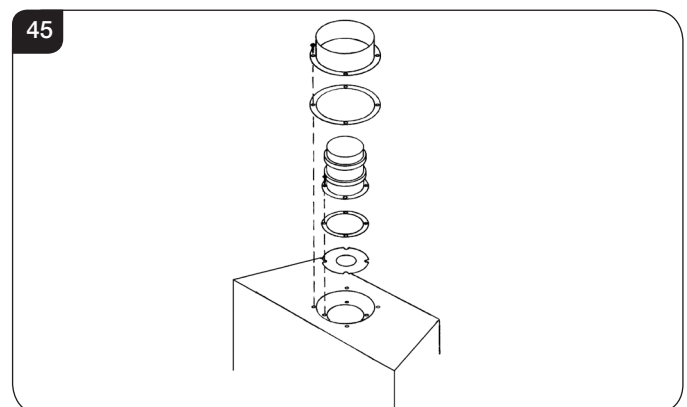

# Installation Instructions

6.2 A 152mm (6") diameter hole in the wall is required to install the flue. This can be achieved by using either:

- a) Core drill
- b) Hammer and chisel

6.3 Drill small holes around the circumference when using method b). Make good both ends of the hole.

6.4 Allow enough room either above or to the side of the appliance to assemble the flue on top.

6.5 Assemble a horizontal flue in the following order:

- Vertical section
- 90° elbow
- Horizontal plus terminal

6.6 Support the opening of a masonry installation with a lintel.]

6.7 Only the horizontal terminal section can be reduced in size.

To find the length:

6.8 Measure from the outside of the wall to the stop on the 90° elbow.

6.9 **Add 10mm to the outlet end.**

6.10 Measure from the edge of the slots closest to the wall.

6.11 Mark around the flue, see Diagram 46.

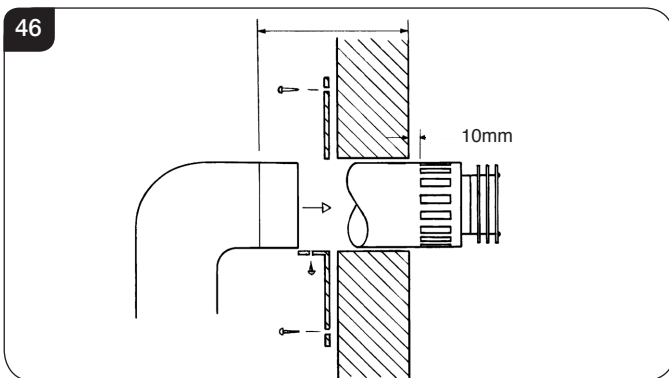

A wall plate is supplied to fix the flue to the wall:

6.12 Bend the tab to 90°.

6.13 Assemble the plate onto the flue but do not secure to wall until the flue is fully assembled, see Diagram 46.

6.14 The cardboard fitment in the terminal is used to support the flue whilst it is cut to length. **ONCE CUT TO SIZE REMOVE THE CARDBOARD REMNANT**, see Diagram 47.

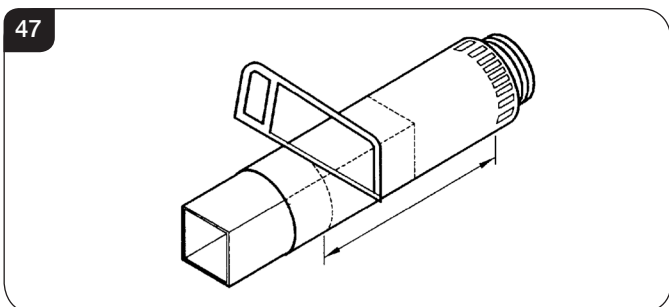

## 7. Gas Supply

7.1 Remove the compression elbow from the appliance and connect it to the gas supply pipe.

As the appliance is fitted into the enclosure:

7.2 Pass the elbow and supply pipe through the opening on the LEFT HAND side.

7.3 **PURGE THE SUPPLY PIPE.** This is essential to expel any debris that may block the gas controls.

7.4 Connect the elbow to the appliance inlet pipe, see Diagram 48.

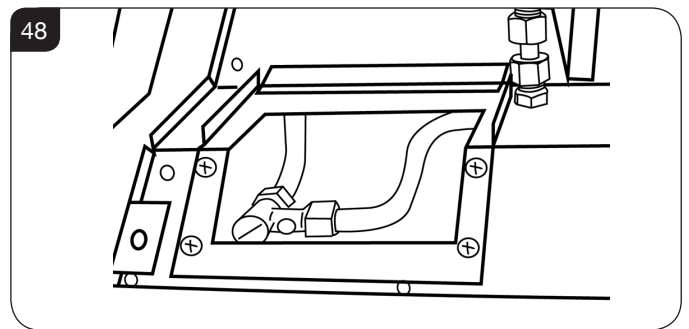

## 8. Gas Soundness Pressure Check

8.1 Connect a suitable pressure gauge to the test point located on the inlet fitting, see Diagram 49. Pass the pressure pipe under main control assembly and out through the gap inside the outer casing, see Diagram 49. Refit the burner unit, turn the gas supply on and perform a pressure drop test to check for leaks in the installation. Light the appliance, turn to maximum and check that the supply pressure is as stated on the databadge. Turn the gas off and replace the test point screw, turn the gas on and check the test point for leaks.

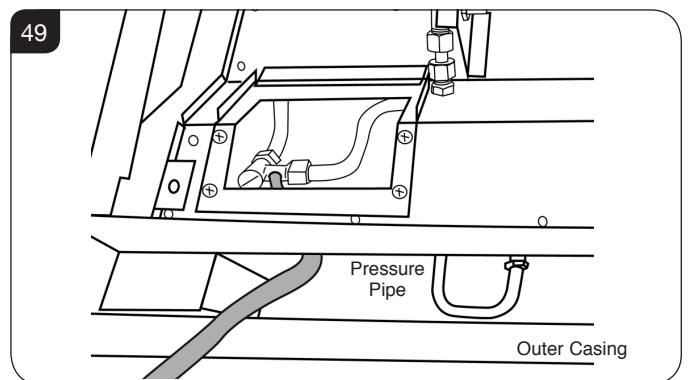

Check the function of the handset, if there is no communication between the remote control and the appliance, see Commissioning Section 2.

# Installation Instructions

## Advice on handling and disposal of fire ceramics



The fuel effect and side panels in this appliance are made from Refractory Ceramic Fibre (RCF), a material which is commonly used for this application.

Protective clothing is not required when handling these articles, but we recommend you follow normal hygiene rules of not smoking, eating or drinking in the work area and always wash your hands before eating or drinking.

To ensure that the release of RCF fibres are kept to a minimum, during installation and servicing a HEPA filtered vacuum is recommended to remove any dust accumulated in and around the appliance before and after working on it. When servicing the appliance it is recommended that the replaced items are not broken up, but are sealed within heavy duty polythene bags and labelled as RCF waste.

RCF waste is classed as stable, non-reactive hazardous waste and may be disposed of at a licensed landfill site.

Excessive exposure to these materials may cause temporary irritation to eyes, skin and respiratory tract; wash hands thoroughly after handling the material.

## 9. Fitting the Liners

- 9.1 Remove the burner unit, see Section 3.7.
- 9.2 The baffle must be removed before the liners can be fitted.
- 9.3 The baffle is held in place by 5 screws, 3 at the front and 2 at the rear, See Diagram 50. The rear screws sit between slotted tabs, once the front screws are removed, loosen the rear screws and slide the baffle forward to remove.

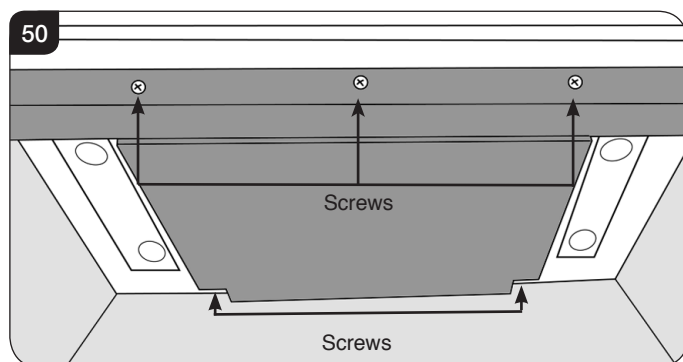

- 9.4 The baffle can now be removed by lowering the front edge and pulling forward through the front of the appliance.  
**TAKE CARE NOT TO DAMAGE THE SIDE PANELS**

- 9.5 Undo the 2 screws to remove the rear log support bracket, see Diagram 51.

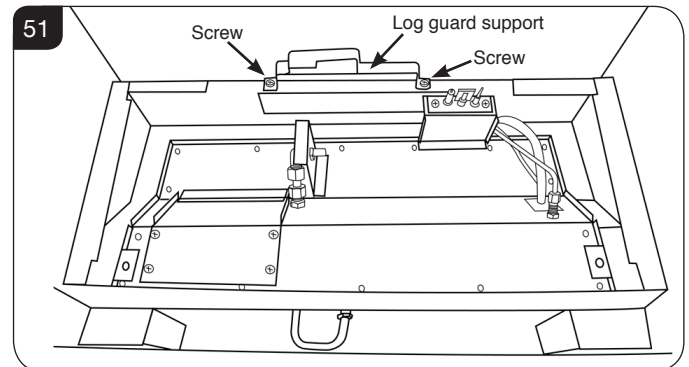

- 9.6 Carefully fit the back liner by twisting slightly to insert through the front of the appliance and lifting over the pilot, see Diagram 52. **Take care not to damage the pilot.**

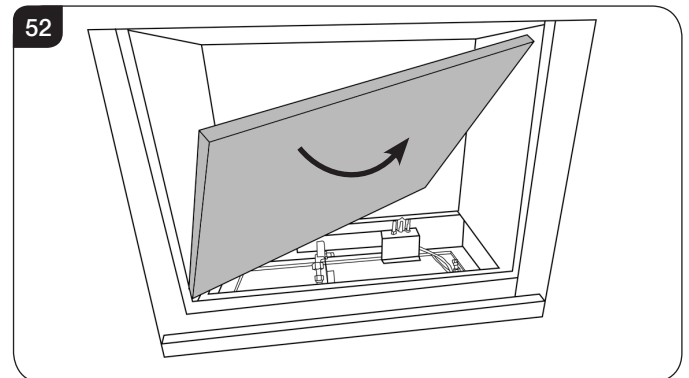

- 9.7 To fit the Right Hand liner insert through the front of the appliance tilting the top inwards towards the centre of the firebox before lowering into position, see Diagram 53.

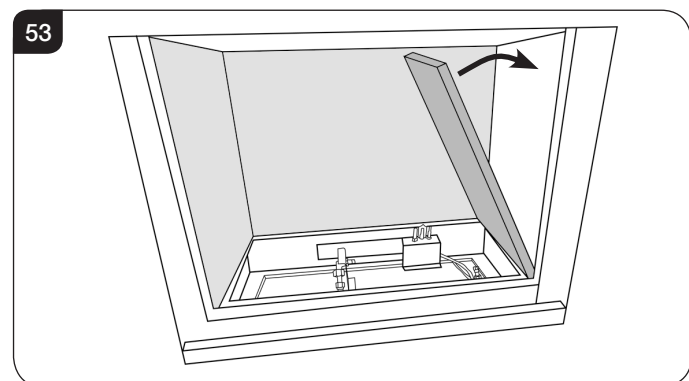

- 9.8 To fit the Left Hand liner insert through the front of the appliance tilting the top inwards towards the centre of the firebox before lowering into position, see Diagram 53.

The 2 side liners also support the rear panel.

- 9.9 Insert the baffle through the front of the firebox.
- 9.10 Replace the 3 screws at the front of the baffle and 2 at the back, to secure it to the roof of the firebox, see Diagram 54.

# Installation Instructions

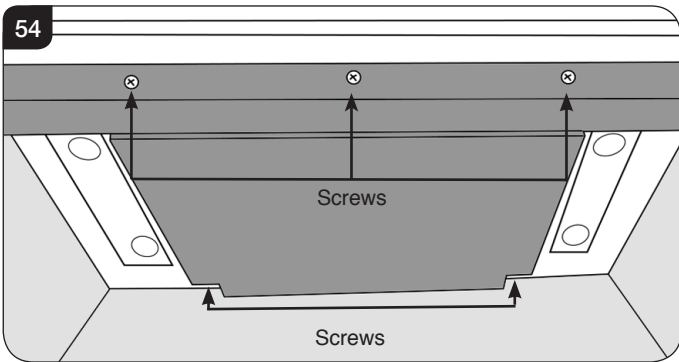

9.11 Replace the burner unit.

Note: When reinstalling the burner unit ensure that the tabs at the back of the burner tray engage in the channel under the back panel.

9.12 Replace the rear log support bracket and secure with the 2 screws, see Diagram 49.

9.13 Fit the 2 lower side panels, see Diagram 55.

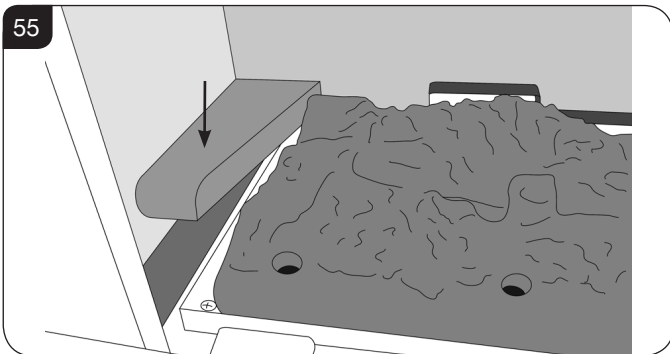

## 10. Arrangement of Fuel Bed Components

**LOGS MUST BE POSITIONED ACCORDING TO THE FOLLOWING INSTRUCTIONS TO GIVE THE CORRECT FLAME EFFECT.**

10.1 Ensure the burner tray is clean and free from any debris.

10.2 The logs for the fuel bed are clearly individually labelled, see Diagram 56.

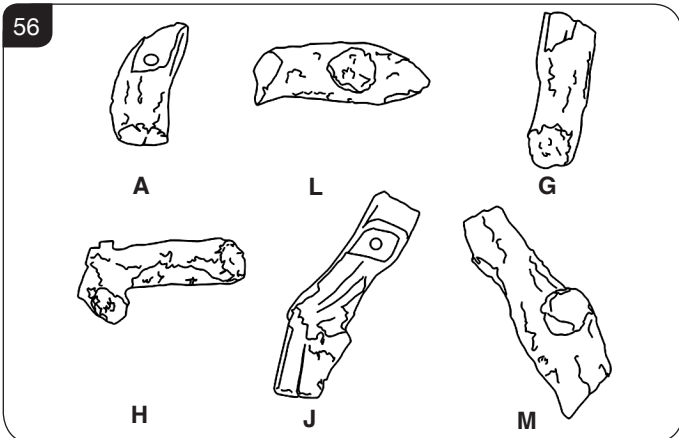

10.3 Place log A on the left hand front of the burner. The log will fit over the raised stud and into the groove in the burner tray, see Diagram 57.

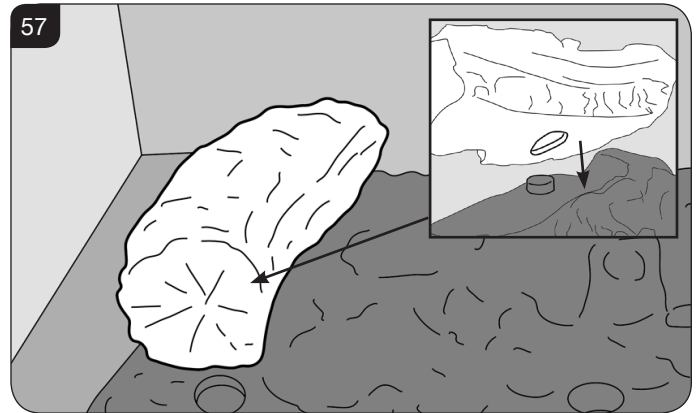

10.4 Place Log L behind the Log A on the flat plain and locate the rear of the log on the metal bracket. The log should rest between the lip of the bracket and the rear liner, see Diagram 58.

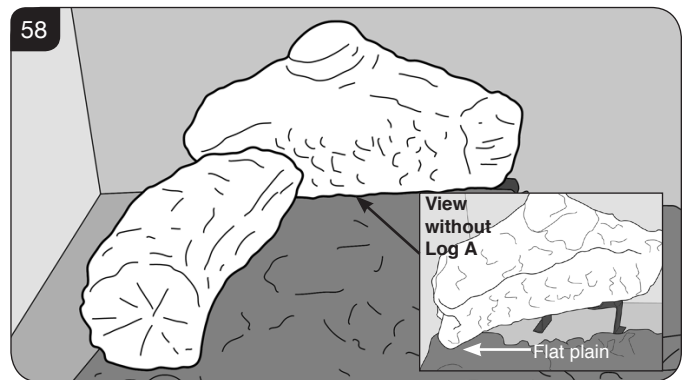

10.5 Place Log G on top of Log A. There is a hole on the underside of Log G which fits over the raised stud on Log A to secure in place. The end of the log sits on the raised section of the burner tray, see Diagram 59.

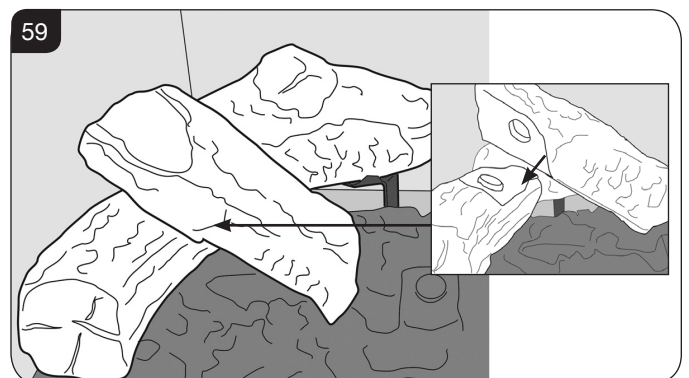

10.6 Place Log H on the centre of the burner tray. There is a raised stud in the fuel bed which securely locates the log in place. The right hand side rests on the raised section at the end of the air cutout, see Diagram 60.



# Installation Instructions

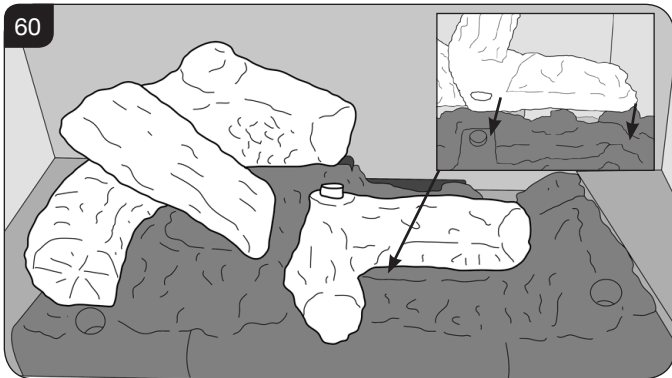

10.7 Rest Log J on the raised stud on Log H. The rear of the effect should rest on the metal bracket at the back of the burner tray, see Diagram 61.

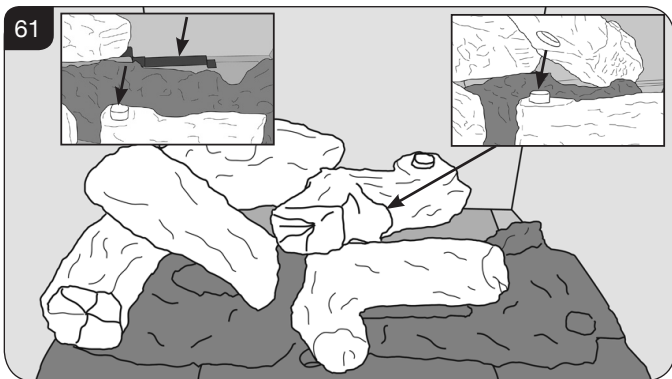

10.8 Sit the first hole in the bottom of the left hand side of Log M on the stud of Log H and secure by fitting the middle hole on the right hand side over the stud in the fuel bed by the burner port, see Diagram 62.

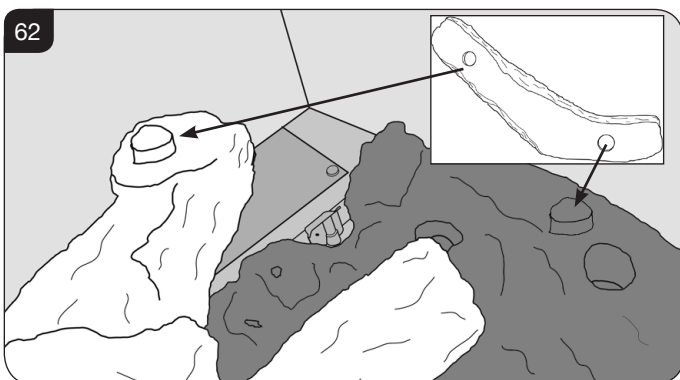

10.9 Log M should rest on the flat plain behind the stud for the Log arrangement to be complete, see Diagram 63.

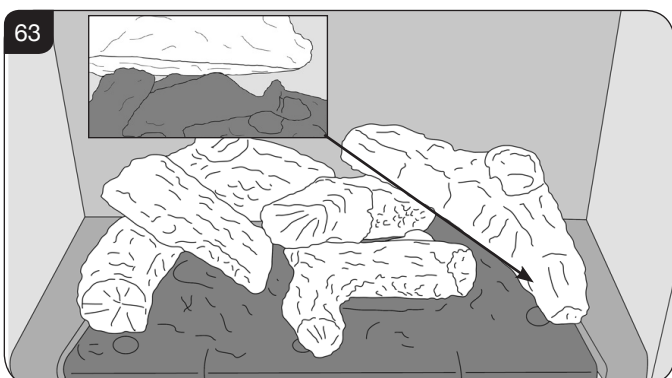

10.10 Place the small pieces of bark down either side, see Diagram 64.

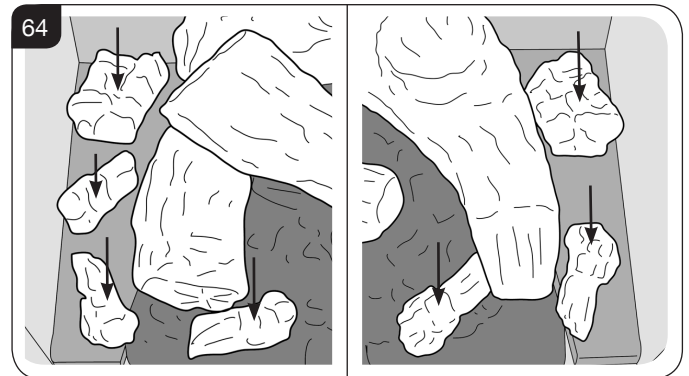

10.11 Lay emberglow over the small ports in the base of the burner tray. This will create a glowing effect when the appliance is lit, see Diagram 65.

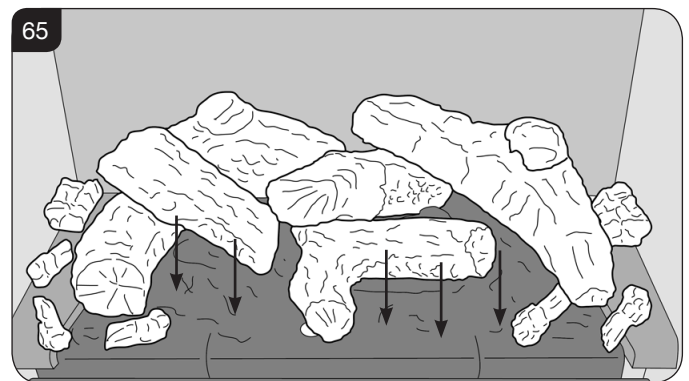

**NOTE: ENSURE THAT THE LOGS ARE POSITIONED AS ABOVE. ONLY USE THE CORRECT AMOUNT OF LOGS AS SPECIFIED IN THE DIAGRAMS.**

## 11. Completion of Assembly

Ensure that the fibreglass seal on the back of the glass frame is intact.

11.1 To replace the glass frame, position so the hooks on the back of the frame fit over the side pins, see Diagram 66.

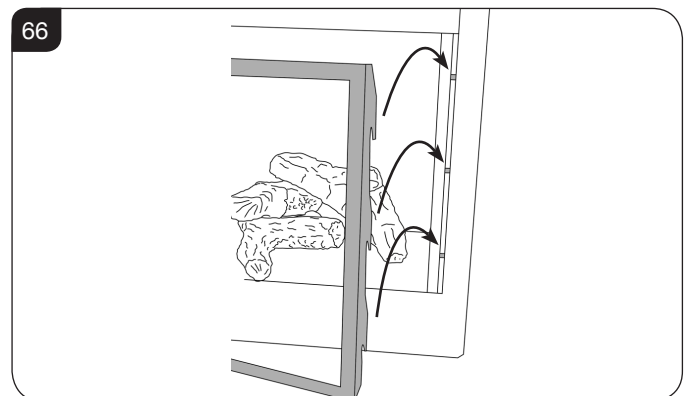

11.2 Push the handle down.

# Installation Instructions

- 11.3 Replace the screws. As the screws are tightened the glass frame is pulled down against the hooks and forms a seal. **Replace ALL of the securing screws ensuring that a screw is present in all fixing slots.**



**UNDER NO CIRCUMSTANCES SHOULD THE APPLIANCE BE USED IF ANY OF THE GLASS FRAME RETAINING SCREWS ARE LOOSE OR MISSING.**

- 11.4 Replace the lower trim to cover the gap at the bottom of the window. The louvres point forwards.
- 11.5 Replace the 2 magnetic side trims.

**NEVER OPERATE THE APPLIANCE WHEN THE GLASS PANEL IS REMOVED OR BROKEN.**

## 12. Operating the Appliance

- 12.1 The appliance has 4 flame settings:
1. High.
  2. Medium.
  3. Low.
  4. Standby (Pilot only).
- 12.2 Both touch pad and handset allow you to manually switch between flame settings.
- 12.3 The Thermostatic handset also allows to set the appliance to automatically regulate the room temperature.

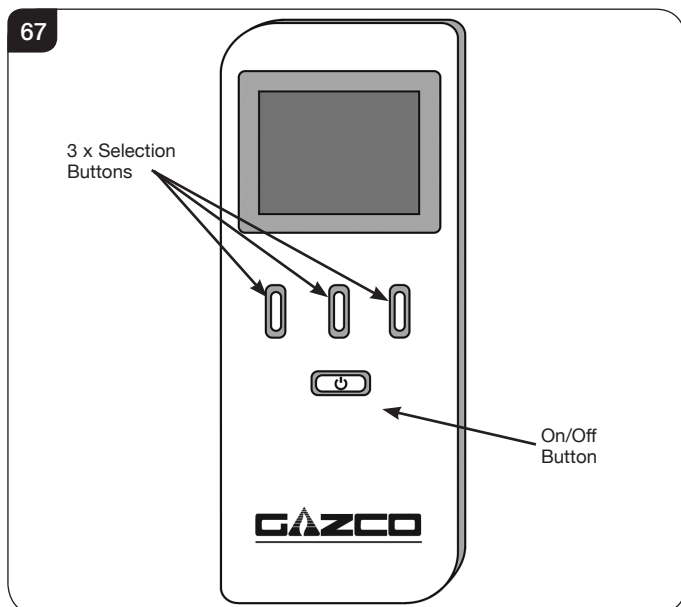

### Before using the remote control:

- 12.4 If there is no display on the LCD screen press any key.

- 12.5 When first powered, the handset displays the OFF screen. The handset may be locked as indicated by the padlock symbol (🔒), see Diagram 68.

**NOTE: To select a function from the options displayed at the bottom of the screen press the button directly below the desired function.**

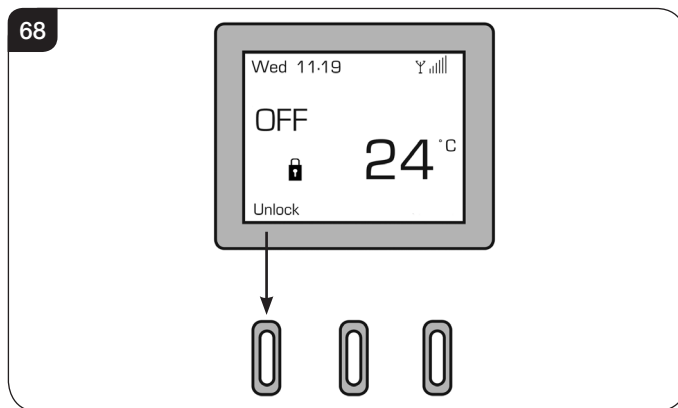

- 12.6 To unlock the handset select Unlock followed by OK - the symbol will change to an open padlock (🔓).
- 12.7 There are 3 different modes available for controlling and operating the appliance for full operating details see Section 2, User Instructions.

When a command from the handset is received a beep will sound and the LED on the handset will briefly illuminate.

**NOTE:** The LED flashes every 4 seconds to show that it is communicating with the appliance. After each command has been accepted the LED will cease flashing until the command has been carried out. Wait until the LED resumes flashing before giving another command.

## Manual Mode

### Switching the Appliance ON:

- 12.8 To light the appliance press the On/Off (🔌) button, this will bring up the LCD screen. Select the 'On' option on the left of the screen immediately followed directly by the OK button, a single beep will sound.

After the start up cycle has completed the appliance will light on the high flame setting (this can take up to 20 seconds).

Select the 'Manual' option on the screen to control the appliance.

### Decreasing the Flame Height:

- 12.9 From the high flame setting press DOWN (↓) once to lower the flame to the medium setting.
- 12.10 From the medium flame setting press DOWN (↓) once to lower the flame to the low setting.
- 12.11 From the low flame setting press DOWN (↓) once to put the appliance in Standby mode (Pilot only).

### Increasing the Flame Height:

- 12.12 To light the appliance when it is in Standby mode press UP (↑) once. The appliance will light on the **Low** flame setting.
- 12.13 From the low setting press UP (↑) once to increase the flame setting to medium.
- 12.14 From the medium setting press UP (↑) once to increase the flame setting to high.



**WARNING: IF THE APPLIANCE FAILS TO LIGHT OR BECOMES EXTINGUISHED IN USE, WAIT 3 MINUTES BEFORE ATTEMPTING TO RELIGHT.**



**IMPORTANT: YELLOW FLAMES TYPICALLY APPEAR WHEN THE APPLIANCE HAS REACHED NORMAL OPERATING TEMPERATURE. THIS CAN TAKE UP TO 30 MINUTES.**

### Switching the Appliance OFF:

- 12.15 To switch the appliance OFF press the On/Off (⏻) button once, see Diagram 67.

**FOR FULL OPERATING INSTRUCTIONS AND TROUBLESHOOTING SEE USER SECTION.**

## 13. Touch Pad Control

69



The touch pad control is located on the front of the wall switch and allows manual operation of the appliance, see Diagram 69.

With the touch pad it is possible to turn the appliance ON, OFF and control the flame setting.

**NOTE:** When using the touch pad buttons a beep will be emitted from the appliance to indicate an accepted command.

### Lighting the appliance

- 13.1 Press the On/Off button once.  
  
If the pilot fails to light, press the ON/OFF button to switch OFF. Wait for at least 30 seconds before attempting to relight.
- 13.2 After the start up cycle has completed the appliance will light on the **high flame setting** (this can take up to 20 seconds).  
  
If the appliance is in Standby mode, pressing the UP (↑) button will cause the main burner to ignite on the **Low** flame setting.
- 13.3 To increase the flame height press the UP (↑) button.
- 13.4 To decrease the flame height press the DOWN (↓) button.
- 13.5 When on the lowest flame setting pressing the Down (↓) button will switch the appliance to Standby mode (pilot only).



**WARNING: IF THE APPLIANCE FAILS TO LIGHT OR BECOMES EXTINGUISHED IN USE, WAIT 3 MINUTES BEFORE ATTEMPTING TO RELIGHT.**



**IMPORTANT: YELLOW FLAMES TYPICALLY APPEAR WHEN THE APPLIANCE HAS REACHED NORMAL OPERATING TEMPERATURE. THIS CAN TAKE UP TO 30 MINUTES.**

### To Switch the Appliance OFF:

- 13.6 To turn the appliance **OFF** press the On/Off button once.

## Touch Pad Control Not Working

**If the appliance is not operating with the touch pad control:**

- 13.7 Replace the batteries in the wall switch unit, see Section 6, User Instructions.
- 13.8 If the appliance still fails to operate consult your installer or Gazco retailer.

# Commissioning

## 1. Commissioning

- 1.1 Complete the Commissioning Checklist at the front of this manual covering:
- Flue checks
  - Gas checks
  - Log/fuel effect layout - flame picture
- For working pressure test, ensuring the burner is in position, refer to Installation Instructions Section 8.
- 1.2 Ensure all safety checks listed in the Commissioning Section are completed, paying particular attention to the glass panel checks and securing of the glass frame.
- 1.3 Upon completion of the commissioning and testing of the installation and correct operation of the appliance, the installer must instruct the user how to operate the appliance.
- 1.4 Guide the user through the User Instructions paying particular attention to:
- a) Regular servicing (Section 11 of the User Instructions).
  - b) Ventilation (Section 12 of the User Instructions) - point out the ventilation positions where applicable.
  - c) Hot surfaces (Section 14 of the User Instructions).
  - d) How the appliance works with the touch pad control (Section 5 of the User Instructions).
  - e) How the appliance works with the remote control handset and the modes of operation (Section 2 of the User Instructions).
  - f) How to change settings in the auto mode and program modes of operation.
  - g) What to do if the appliance fails to operate (Section 15 of the User Instructions).

## 2. Pairing the appliance



**To access the control panel in order to pair the appliance it will be necessary to remove the Main Control Assembly, see Servicing Section 4.**

If there is no communication between the remote control and the appliance after replacing the control box or the handset, it will be necessary to pair the two together.

**Before starting the pairing process ensure the handset is programmed to Channel 'C' see Section 3.**

- 2.2 Ensure batteries are fitted and working in the handset.
- 2.3 Check all leads and cables are connected correctly.
- 2.4 Ensure the handset is unlocked. To unlock the handset select Unlock followed by OK - the symbol will change to (☑).

- 2.5 Press the ON/OFF button (⏻) on the handset and keep it depressed until the screen changes to the configuration menu. This may take up to 30 seconds and the screen may go blank before changing to the configuration screen.
- 2.6 When the configuration menu screen appears change the Pairing option to ON using the Change button.
- 2.7 Within 20 seconds press the yellow button on the control unit repeatedly until a single beep is heard confirming the pairing operation has been successful, see Diagram 1. This may be easier using a pencil, ball point pen or similar.

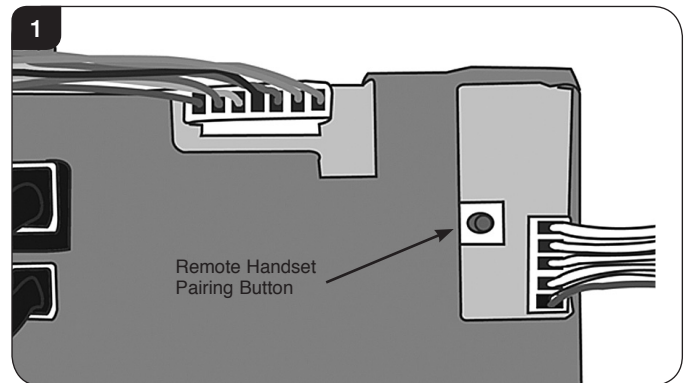

- 2.8 The remote handset will display a signal level in the top right hand corner. This may take up to 4 minutes.
- 2.9 Press the back button on the handset to return to the configuration menu and then again to return to the main menu.

## 3. Changing channel



**WHEN ATTEMPTING A NEW PAIRING PROCEDURE THE HANDSET SHOULD BE SET TO CHANNEL 'C'. IF THE APPLIANCE IS ALREADY SET TO CHANNEL 'C' BUT NO COMMUNICATION SIGNAL STRENGTH IS SHOWN ON THE HANDSET, IT WILL BE NECESSARY TO CHANGE THE COMMUNICATION CHANNEL USING THE FOLLOWING PROCEDURE.**

- 3.1 Ensure the handset is unlocked. To unlock the handset select Unlock followed by OK - the symbol will change to (☑).
- 3.2 Press the ON/OFF button (⏻) on the handset and keep it depressed until the screen changes to the configuration menu. This may take up to 30 seconds and the screen may go blank before changing to the configuration screen.
- 3.3 Press the button below the down arrow (↓) to scroll through the menu until 'Channel' is displayed.
- 3.4 The channel is normally pre-set to C. Press the button below 'Select' and then use the down arrow (↓) to set the handset to channel A or B.
- 3.5 Disconnect the batteries from the control box and reconnect after 10 seconds.
- 3.6 The remote handset will display a signal level in the top right hand corner. This may take up to 4 minutes, check the strength of the signal in the top right hand corner of the LCD display (☑ [signal strength]).

# Servicing Instructions

## Servicing/Fault Finding Charts

### 1. Servicing Requirements

**IMPORTANT** – The glass panel on this appliance should be checked for any signs of damage on the front face of the glass panel (scratches, scores, cracks or other surface defects). If damage is observed, the glass panel must be replaced and the appliance must not be used until a replacement is installed. Under no circumstances should the appliance be used if any damage is observed. Please isolate the appliance until a replacement glass panel has been obtained and installed. Replacement glass panels can be purchased from Gazco via the retailer from which the appliance was purchased or any other Gazco distributor.

This appliance must be serviced at least once a year by a competent person.

All tests must be carried out in accordance with the current Gas Safe recommendations.

#### 1.1 Before Testing:

- Conduct a gas soundness test for the property ensuring there are no leaks before servicing.
- Check the operation of the appliance before testing.

#### 1.2 Special checks:

- Clean the burner using a vacuum cleaner with a soft brush attachment. Ensure all debris is removed from the burner ports.
- Clean away lint or fluff from the pilot.
- Clean away lint or fluff from under the burner.
- Check the spark gap on the pilot is correct.
- Ensure that the glass frame is secured correctly and that all retaining screws are in place.

#### 1.3 Correct any faults found during the initial test.

#### 1.4 Re-commission the appliance in accordance with Commissioning Procedures of these instructions.

#### 1.5 Advise the customer of any remedial work undertaken.

**REPLACE BATTERIES BEFORE ATTEMPTING TO RECTIFY ANY FAULTS.**

### IGNITION FUNCTIONAL CHECK 1

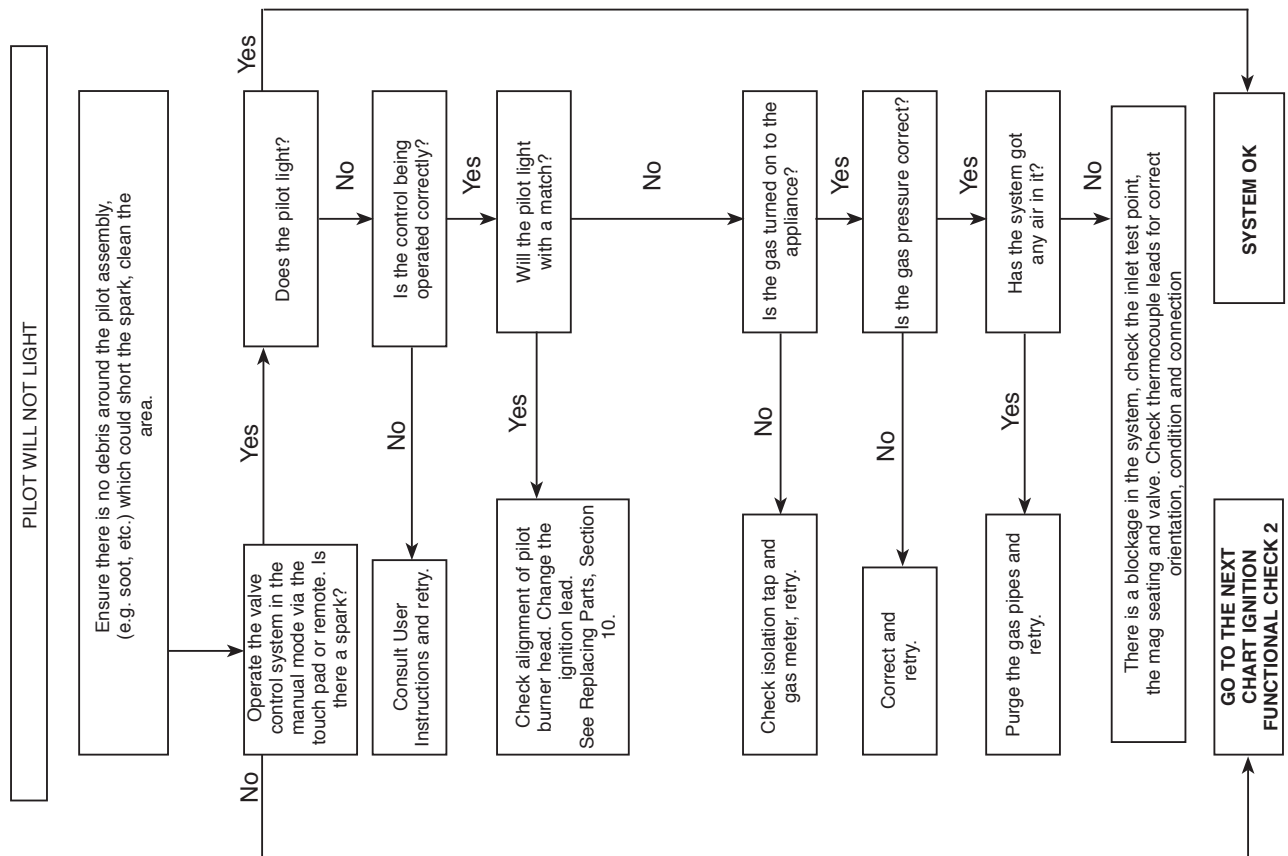



# Servicing Instructions

## Fault Finding Charts

### ELECTRONIC CONTROL VALVE FAULT ANALYSIS

Problem	Cause	Error Message	LCD Display	Solution	
Does not ignite	No batteries or flat batteries in battery box	10 beeps	BATTERY ERROR	Place new batteries in battery box	
	ROM error	2 cycles of 3 beeps	ROM ERROR	Change control unit	
	Support test error	2 cycles of 5 beeps	SUPPORT ERROR	Connect earth cable from control box to valve	
	Bad reception of remote handset signal				Change batteries in the remote handset
					Check the reception of signal from a shorter distance
					Try pairing again
				Try changing the channel in the configuration menu	
	No response to touch control buttons	If LED is continuously on, the cable is connected the wrong way round			Ensure the touch control cable is correctly connected (see installation manual)
Cable loose or broken or connected wrong way round				Change touch control	
Supply cable to valve disconnected or broken	2 cycles of 5 beeps	SUPPORT ERROR	Reconnect or replace valve cable		
Ignition cable disconnected or broken			Connect ignition cable		
Sparks but no pilot ignition	Gas valve supply off or no gas			Check gas installation. Open gas valve	
	Valve cable disconnected or broken			Connect valve cable correctly	
	Interrupter cable disconnected or broken			Connect correctly or replace pilot cable	
Pilot ignites but does not stay on	Pilot is not warmed up			Check pilot flame and verify that it heats the pilot	
	Interrupter cable badly connected			Change polarity of pilot cable	
	Interrupter cable disconnected or broken			Connect pilot cable	
Ignites from remote handset but not from touch pad	Touch control cable disconnected or broken			Connect or replace touch control cable	
	Defective touch control buttons			Change touch control	
Ignites from touch pad but not from remote	Bad communication with handset			Check batteries in handset	
				Check reception of signal from a shorter distance	
				Try pairing again	
				Try changing the channel in the configuration menu	
Switches off after 6 seconds	Short circuit in touch control	5 beeps	BUTTON ERROR	Change touch control wiring	
Low batteries on remote			Low battery	Change the batteries in the remote	
Appliance switches off		2 cycles of 3 beeps	CONFIG ERROR	Change control unit	
		2 cycles of 3 beeps	EEPROM ERROR	Try pairing again	
				Change control unit	
	Loss of communication between appliance and remote for 18min	20 beeps		The remote is too far from the appliance	
				Replace batteries in handset	
	High temperature on control unit	1 long beep	TEMP ERROR	If this occurs more than once call the technical service	
	Ambient temperature higher than configured		Over Temperature	Check the correct configuration of safety temperature	

# Servicing Instructions

## 1. General

- 1.1 All principal components can be replaced without removing the appliance from its installation, although it is essential that the gas supply to the appliance is turned off at the isolation device before proceeding further.
- 1.2 It will be necessary to remove the Main Burner before any of the components can be serviced.

## 2. Removing the Glass Frame

- 2.1 Remove the glass frame by removing the 2 side trims, see Diagram 1. These are held on by magnets.

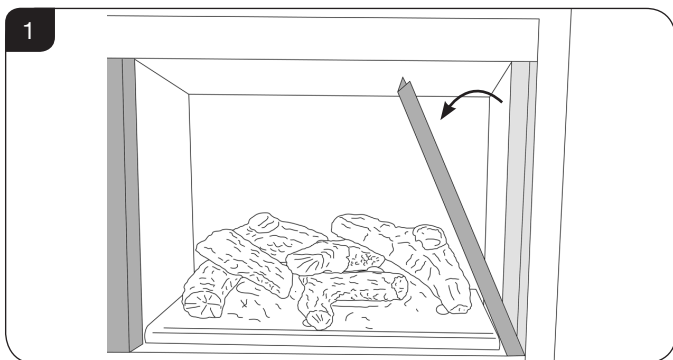

- 2.2 Lift out the bottom slotted trim, see Diagram 2. Note the orientation of the metal shield for reassembly.

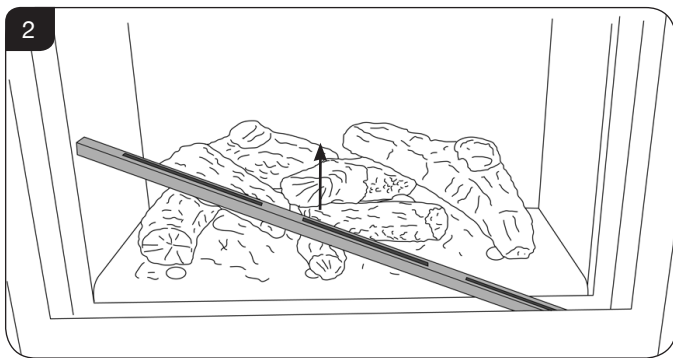

- 2.3 Remove the 2 screws at the base of the glass frame, see Diagram 3.

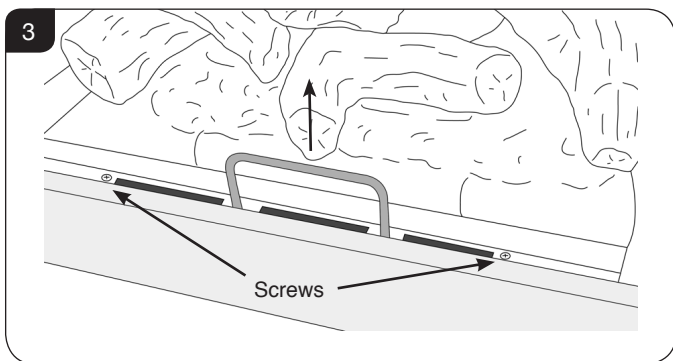

- 2.4 Pull up the handle at the front, see Diagram 3.
- 2.5 Whilst supporting the top, lift the glass frame using the handle, up and over the lower edge, see Diagram 4.

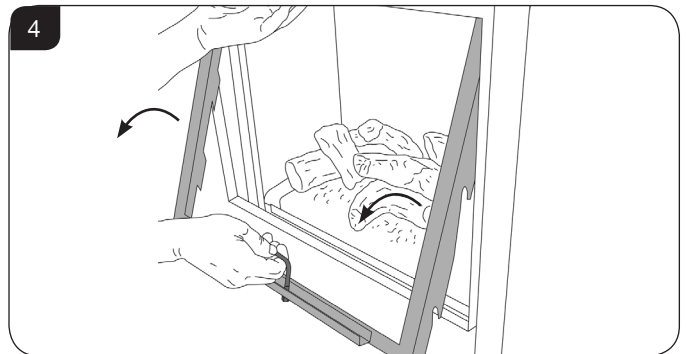

- 2.6 Remove the logs, and place them on a dry, clean surface.

**When refitting the glass frame ensure that the fibreglass seal on the back of the frame is intact.**

- 2.7 To replace the glass frame, position so the hooks on the back of the frame fit over the side pins, see Diagram 4.
- 2.8 Push the handle down.
- 2.9 Replace the screws. As the screws are tightened the glass frame is pulled down against the hooks and forms a seal. **Replace ALL of the securing screws ensuring that a screw is present in all fixing slots.**



**UNDER NO CIRCUMSTANCES SHOULD THE APPLIANCE BE USED IF ANY OF THE GLASS FRAME RETAINING SCREWS ARE LOOSE OR MISSING.**

- 2.10 Replace the lower trim to cover the gap at the bottom of the window. The louvres point forwards.
- 2.11 Replace the 2 magnetic side trims.

**NEVER OPERATE THE APPLIANCE WHEN THE GLASS PANEL IS REMOVED OR BROKEN.**

- 2.12 The glass front must be refitted to the appliance following cleaning or servicing.

## 3. Main Burner

- 3.1 As a safety precaution remove the batteries from the wall box, see Installation Section 4.
- 3.2 Remove the 2 lower side cover panels, see Diagram 5.

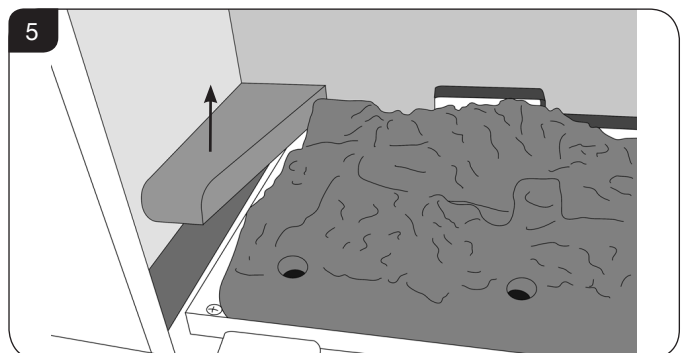



# Servicing Instructions - Replacing Parts

- 3.3 Remove the 2 screws at the front of the burner unit, see Diagram 6.

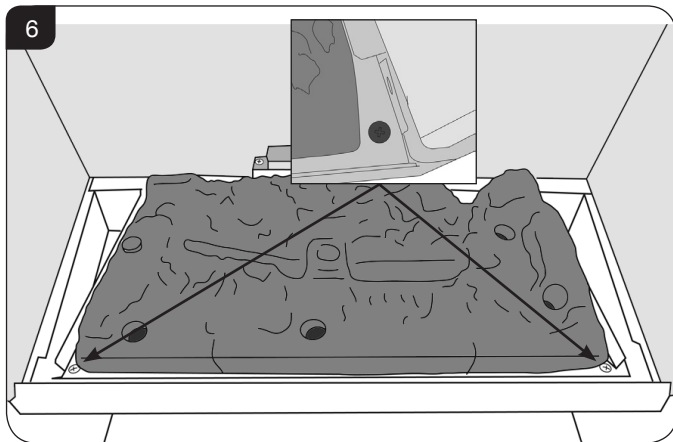

- 3.4 Slide the burner unit to the right, pull slightly forward and lift from the back. Carefully remove through the front of the appliance. Place carefully to one side.

Note: When reinstalling the burner unit ensure that the tabs at the back of the burner tray engage in the channel under the back panel.

## 4. Main Control Assembly

- 4.1 As a safety precaution remove the batteries from the wall box, see Installation Section 4.  
 4.2 Remove the door, see Section 2.  
 4.3 Remove the main burner, see Section 3.  
 4.4 Remove the 4 screws to remove the access plate, see Diagram 7.

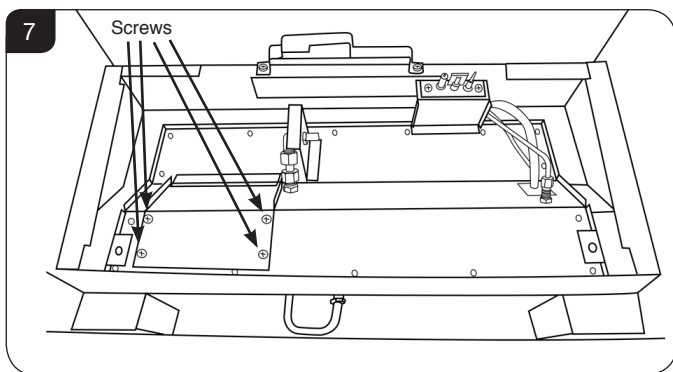

- 4.5 Turn the gas supply off at the isolation device.

### HAVE YOU ISOLATED THE GAS SUPPLY?

- 4.6 Disconnect the isolating device from the appliance inlet pipe to isolate the gas supply, see Diagram 8.

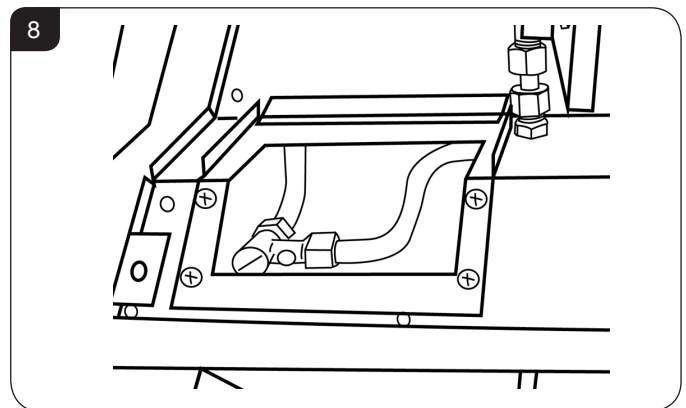

- 4.7 Remove the 15 screws securing the control assembly, see Diagram 9.

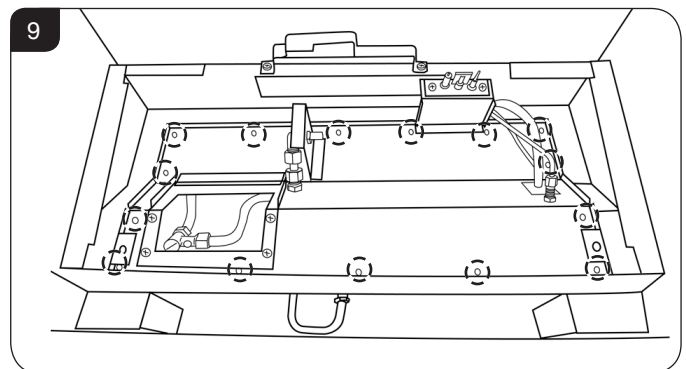

- 4.8 Lift the back of the control assembly and tilt forward to enable access to the controls.  
 4.9 Disconnect the battery supply cable and the touch pad control cable from the control unit.

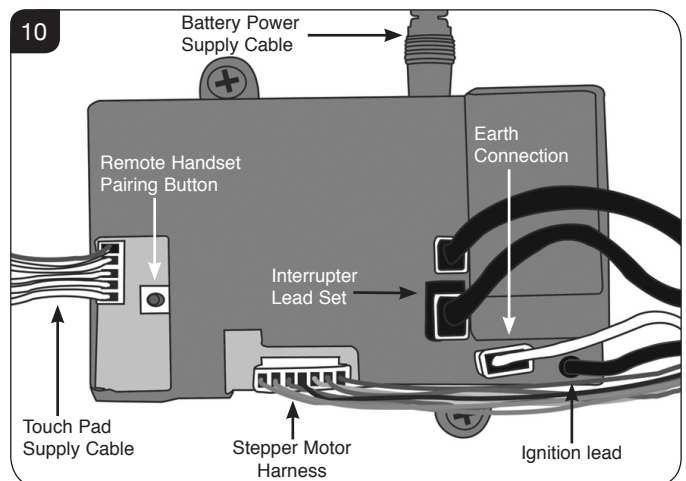

- 4.10 The control assembly can now be lifted and removed through the front of the appliance.

- 4.11 Replace in reverse order.

# Servicing Instructions - Replacing Parts

## 5. Pilot Unit

The pilot assembly consists of four components, which can be individually changed, these are:

- 5a) Pilot burner bracket.
- 5b) Pilot injector
- 5c) Electrode
- 5d) Thermocouple.  
see Diagram 11.

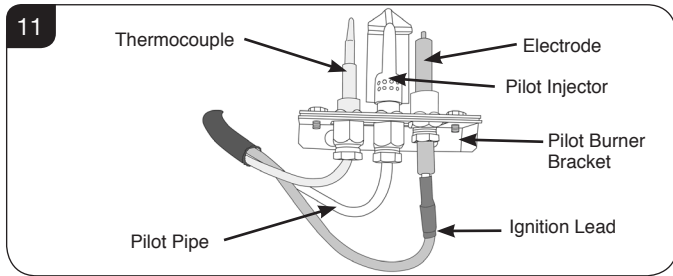

- 5.1 Turn off the gas supply at the isolating device.
- 5.2 Remove the main burner and the main control assembly, see Sections 3 and 4.

## 5a Pilot Burner Bracket

- 5.3 To remove the Pilot Burner Bracket:
  - Disconnect the Ignition lead, see Diagram 11.
  - Loosen thermocouple nut, see Diagram 12.
  - Undo the brass nuts connecting the pilot pipe to the brass fitting and the pilot unit and remove the pilot pipe, see Diagram 12.

**IMPORTANT Ensure not to lose the loose injector component.**

- Remove the 2 screws from the top of the bracket, see Diagram 12.

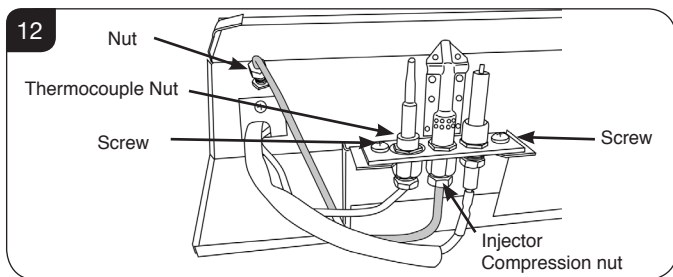

- 5.4 The pilot unit can now be removed and the pilot components can now be individually removed and replace.

## 5b Pilot Injector

- 5.5 Remove pilot burner bracket (see section 5a)
- 5.6 To remove the pilot injector, undo the compression nut to remove the pilot inlet pipe and withdraw the injector, see Diagram 12.

## 5c Electrode

- 5.7 Disconnect the ignition lead and undo the retaining nut, see Diagram 11. Withdraw the electrode from the pilot burner.

## 5d Thermocouple

**IMPORTANT The Ignition lead and the Thermocouple need to be removed at the same time regardless of which needs to be replaced.**

- 5.8 Unplug the Ignition lead from the electrode and undo the brass nut to remove the thermocouple from the pilot burner unit, see Diagram 12.
- 5.9 Undo the brass nut from the back of the interrupter block to disconnect the thermocouple, see Diagram 13.

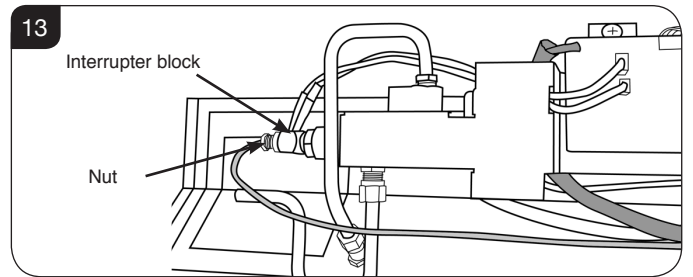

- 5.10 Unplug the Ignition lead from the control box, see Diagram 14.

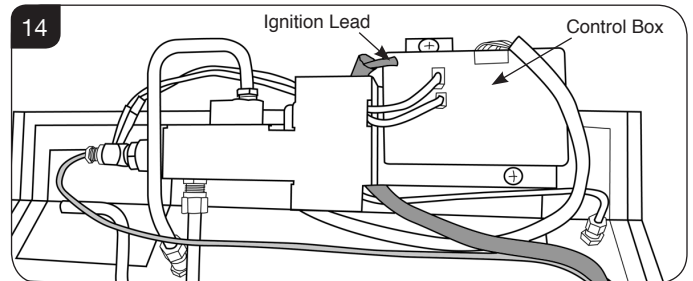

- 5.11 Carefully cut cable ties from the vidaflex.

**IMPORTANT Ensure not to cut the cables.**

- 5.12 Remove screw and sealant from plate, see Diagram 15.

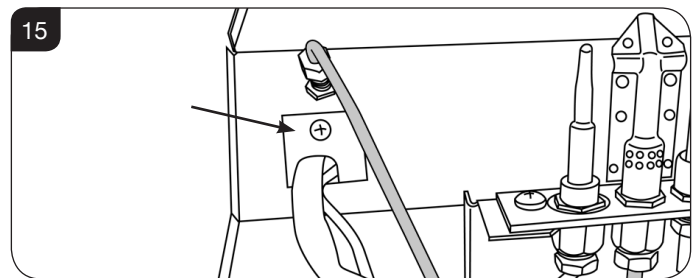

- 5.13 Feed ignition lead and thermocouple complete with vidaflex through metal plate

# Servicing Instructions - Replacing Parts

- 5.14 Withdraw ignition lead and thermocouple from vidaflex sleeve. **THIS MUST BE KEPT AND ASSEMBLED ON THE NEW LEAD. A CABLE TIE MUST ALSO BE USED TO RETAIN THE SLEEVE.**

**IMPORTANT** The cables must follow the same route when they are replaced

- 5.15 When replacing the cover plate ensure silicone sealant is used to seal the aperture.
- 5.16 The cable can only be fitted on way round, ensure this is correct when refitting a replacement.

**IMPORTANT** Ensure that the red end of the ignition cable is reconnected to the electrode.

## 6. Ignition Lead

**IMPORTANT** The Ignition lead and the Thermocouple need to be removed at the same time regardless of which needs to be replaced.

See Section 5d.

## 7. Gas Valve

- 7.1 Remove the main burner and the main control assembly, see Sections 3 and 4.
- 7.2 Disconnect the inlet pipe and feed pipe from the gas valve only, see Diagram 16.

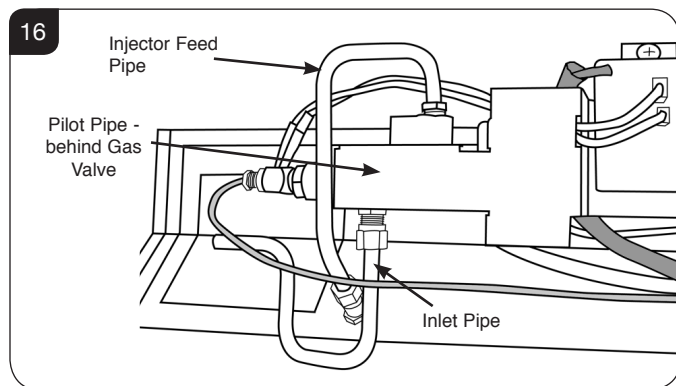

- 7.3 Disconnect the pilot pipe from the gas valve only, see Diagram 17.

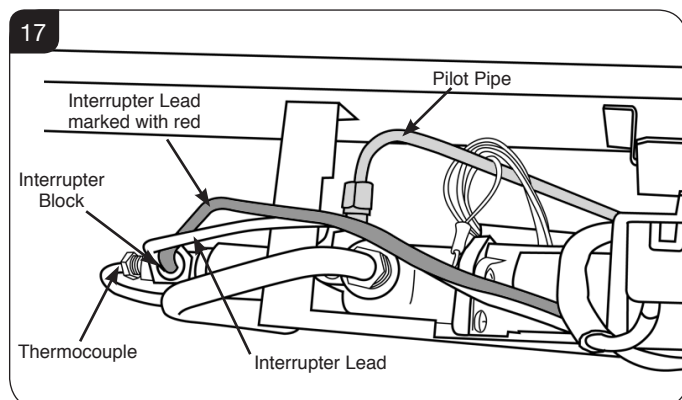

- 7.4 Disconnect the thermocouple, interrupter lead and interrupter block, see Diagram 17.

When replacing the interrupter leads ensure that the lead with the red marking locates nearest the valve, see Diagram 17.

- 7.5 To access the screws securing the valve to the bracket it will be necessary to remove the control box, see Section 9.
- 7.6 Undo the 2 screws to release the valve off the bracket (1 screw is accessible through the hole in the bracket), see Diagram 18.

**DO NOT UNDO THE 2 SCREWS SECURING THE MOTOR TO THE VALVE. THEY WILL REMOVE THE MOTOR FROM THE BODY.**

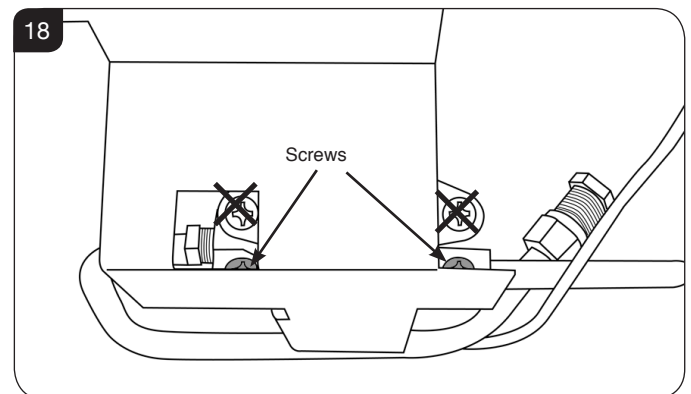

- 7.7 Undo the nut on the back of one of the screws securing the motor to the valve and remove the earth wire, see Diagram 19.

**NOTE:** This must be replaced back in this position.

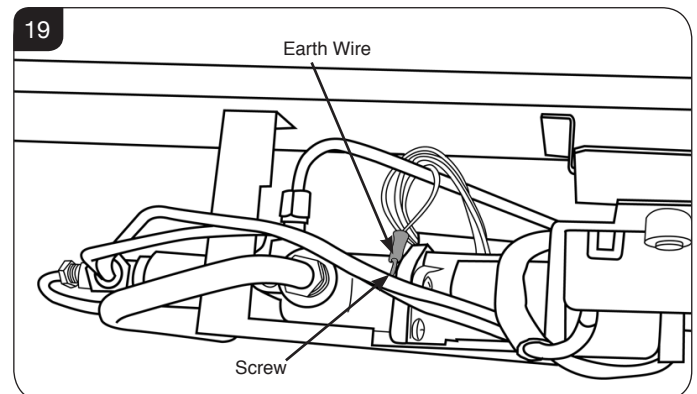

- 7.8 Remove the Stepper motor harness from the control box, see Diagram 21.
- 7.8 Gently remove the valve.
- 7.9 Replace in reverse order and refit the main control assembly and main burner.
- 7.10 Check all joints for leaks, check the operation of the thermocouple and ignition lead.

# Servicing Instructions - Replacing Parts

## 8. Magnetic Safety Valve

- 8.1 Remove the main burner and the main control assembly, see Sections 3 and 4.
- 8.2 Remove the gas valve, see Section 7.
- 8.3 Undo the mag valve retaining nut and gently tap out the mag valve and replace with a new unit. Replace the retaining nut and tighten, see Diagram 20.

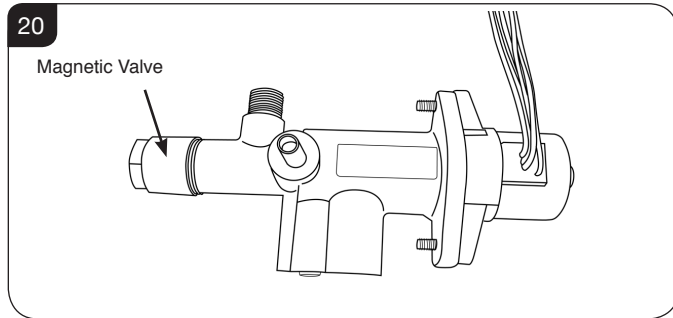

- 8.4 Reassemble the gas valve. Check for leaks after reassembly. Ensure the interrupter leads are in the correct orientation, red lead nearest the valve body.

## 9. Control Box

- 9.1 Undo the 2 screws holding the control box, see Diagram 21.

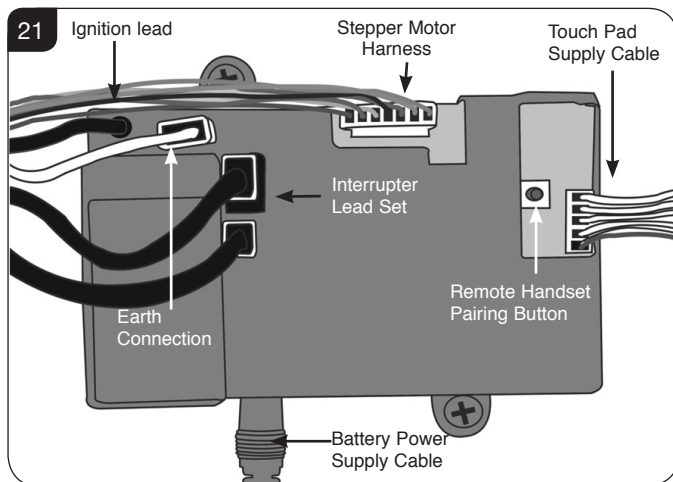

- 9.2 Disconnect from the control box:
  - Ignition lead
  - Interrupter leads
  - Earth connection
  - 7-way stepper motor plug
  - The battery power supply cable
  - The touch pad control cable

See Diagram 21 for details.

The control box can now be replaced.

- 9.3 After replacing the control box ensure all cables connections are refitted, see Diagram 22.

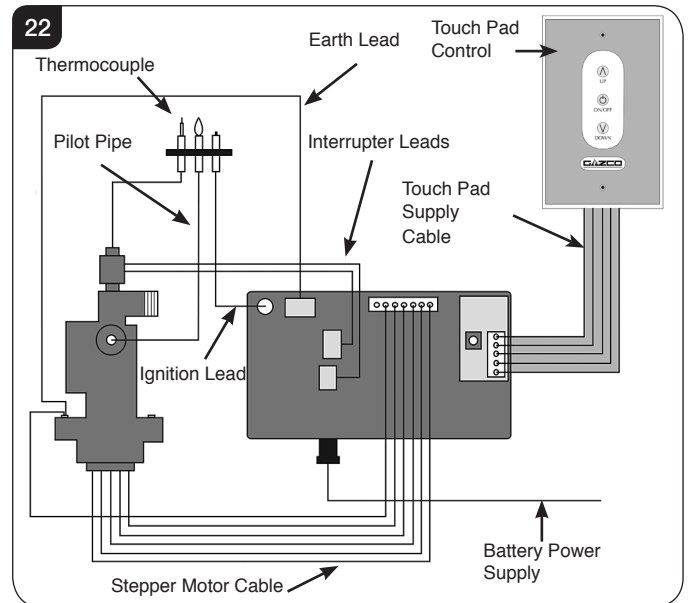

- 9.4 Prior to re-connection of the control box to the appliance, if there is no communication between the remote handset and the appliance, or if the handset is replaced, it will be necessary to pair the handset with the appliance, see Commissioning Section 2.
- 9.5 Ensure batteries are fitted and working in the handset.
- 9.6 Re-fit the touch pad control cable and the battery power supply cable to the control box.

## 10. Main Injector

- 10.1 Remove the main burner, see Section 3.
- 10.2 Undo the 2 nuts and the lock nut, see Diagram 23.

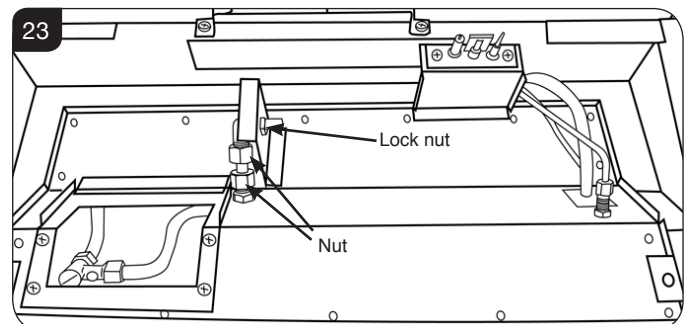

The injector can now be replaced.

- 10.3 Reassemble in reverse order.

# Servicing Instructions - Replacing Parts

## 11. Primary Aeration Plate

- 11.1 Remove the burner unit, see Section 3.
- 11.2 Turn the burn unit over and place on a soft surface so as to not damage the unit.
- 11.3 Undo the 2 nuts to remove the plate, see Diagram 24.

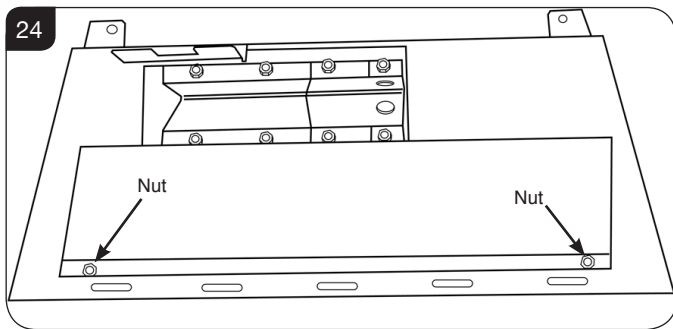

- 11.4 Remove the 2 fixing nuts and slide the plate off the venturi, see Diagram 25, the Aeration Plate can now be replaced.

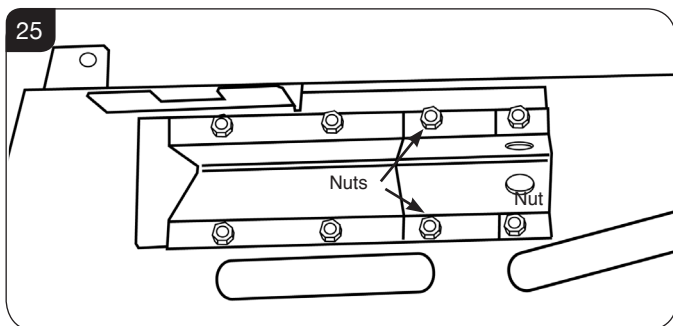

## 12. Baffle & Liners

- 12.1 Remove the 2 lower side cover panels, see Diagram 26.

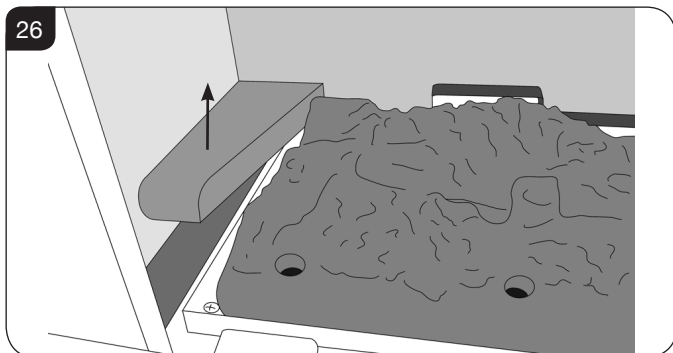

- 12.2 Remove the main burner, see Section 3.
- 12.3 Remove the rear log support brackets, see Diagram 27.

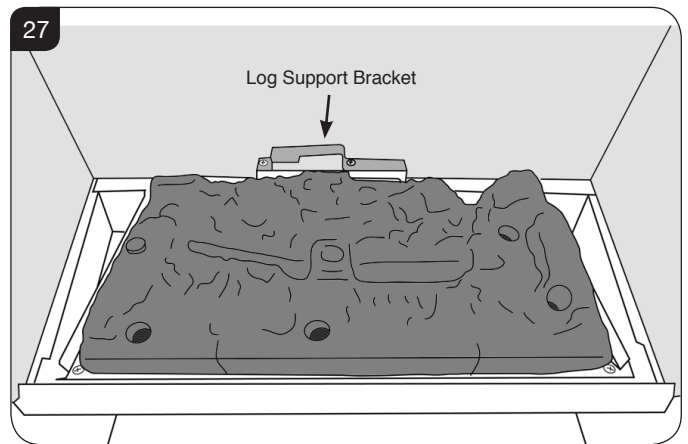

### BAFFLE

The baffle must be removed before the liners can be taken out of the appliance.

- 12.4 The baffle is held in place by 5 screws, 3 at the front and 2 at the rear, See Diagram 28. The rear screws sit between slotted tabs, once the front screws are removed, loosen the rear screws and slide the baffle forward to remove.

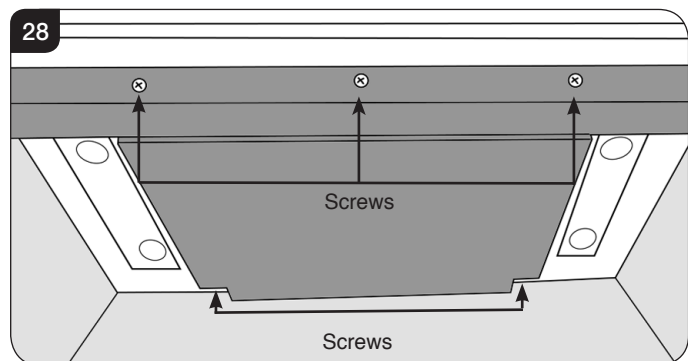

- 12.5 The baffle can now be removed by lowering the front edge and pulling forward through the front of the appliance. **TAKE CARE NOT TO DAMAGE THE SIDE PANELS**

### LINERS

Once the baffle has been placed carefully to one side the liners can then be taken out in the following order.

- 12.6 To remove the Right Hand liner first tilt inwards towards the centre of the firebox before lifting up and pulling out through the front of the firebox, see Diagram 29.

# Servicing Instructions - Replacing Parts

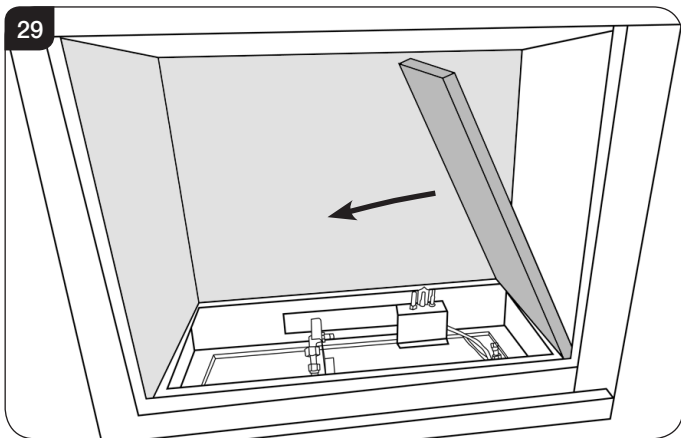

12.7 To remove the Left Hand liner first tilt inwards towards the centre of the firebox before lifting up and pulling out through the front of the firebox, see Diagram 29.

The 2 side liners also support the rear liner.  
Taking out the side liners will allow the rear liner to drop down so ensure it is supported.

12.8 Carefully remove the back liner by tilting the top forward and lifting over the pilot. Twist slightly to allow it to be removed through the front of the appliance, see Diagram 30.  
**Take care not to damage the pilot.**

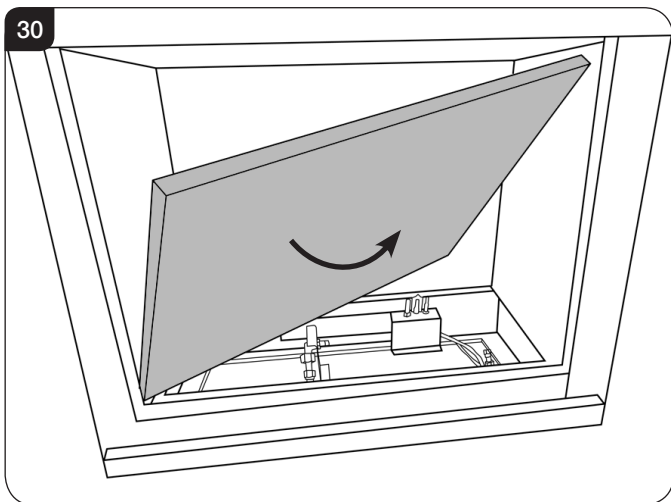

12.9 To replace the liners and baffle reverse these procedures.

## 13. Changing Between Gas Types

In order to change between gas types, it will be necessary to change the following components:

- Gas Valve
- Main Injector
- Pilot Injector
- Data Badge
- Primary Aeration Plate

Always quote the Model number and Serial number when ordering any spare parts.

# Servicing Instructions - Replacing Parts

## 14. Short Spares List

COMPONENT	Riva2 500	
	NG	LPG
PILOT BURNER	PI0069	PI0070
MAIN INJECTOR	IN0045	IN0055
BURNER UNIT	GZ9963	GZ9963
AERATION PLATE	G20 - GZ11271	G31 - GZ10412
GAS VALVE Gas Valve is pre-set for the appliance	GC0170	GC0172
THERMOCOUPLE	PI0074	
PILOT INJECTOR	PI0026	PI0015
SPARK ELECTRODE	PI0075	
MAG UNIT	GC0109	
IGNITION LEAD	EL0508	
CONTROL BOX	EL0575	
REMOTE CONTROL	EL0574	
INTERRUPTER BLOCK	GC0026	
INTERRUPTER LEADS	EL0316	
WALL PLATE	EL0501	
WALL PLATE CABLE 3M	EL0504	
BATTERY HOLDER	EL0503	
TOUCH PAD, BATTERY, WALL PLATE & LEAD	EL0502	
BLACK REED LINING SET	934-159	
VERMICULITE LINING SET	934-181	
BRICK EFFECT LINING SET	934-203	
LOG SET	CE1058	
EMBERGLOW	8471	
WINDOW FRAME ASSEMBLY	GZ10986	

# Service Records

## 1ST SERVICE

Date of Service:.....

Next Service Due:.....

Signed:.....

Retailer's Stamp/Gas Safe Registration Number

## 3RD SERVICE

Date of Service:.....

Next Service Due:.....

Signed:.....

Retailer's Stamp/Gas Safe Registration Number

## 5TH SERVICE

Date of Service:.....

Next Service Due:.....

Signed:.....

Retailer's Stamp/Gas Safe Registration Number

## 7TH SERVICE

Date of Service:.....

Next Service Due:.....

Signed:.....

Retailer's Stamp/Gas Safe Registration Number

## 9TH SERVICE

Date of Service:.....

Next Service Due:.....

Signed:.....

Retailer's Stamp/Gas Safe Registration Number

## 2ND SERVICE

Date of Service:.....

Next Service Due:.....

Signed:.....

Retailer's Stamp/Gas Safe Registration Number

## 4TH SERVICE

Date of Service:.....

Next Service Due:.....

Signed:.....

Retailer's Stamp/Gas Safe Registration Number

## 6TH SERVICE

Date of Service:.....

Next Service Due:.....

Signed:.....

Retailer's Stamp/Gas Safe Registration Number

## 8TH SERVICE

Date of Service:.....

Next Service Due:.....

Signed:.....

Retailer's Stamp/Gas Safe Registration Number

## 10TH SERVICE

Date of Service:.....

Next Service Due:.....

Signed:.....

Retailer's Stamp/Gas Safe Registration Number









**Gazco Limited, Osprey Road, Sowton Industrial Estate, Exeter, Devon, England EX2 7JG**  
**Technical Customer Services: (01392) 261950 Fax: (01392) 261951**  
**E-mail: [technicalservices@gazco.com](mailto:technicalservices@gazco.com)**

A member of the Stovax Group

E & O E